

Safematic

Electronic pump protection

This unit stops the pump when is detected a dry-running operation or an overload. It has an integrated Schuko socket for the pump connection. It has also a Schuko plug for the power supply connection, in case of other socket shapes there is a wall-mounted variant where the connection is performed through the lateral PG's.

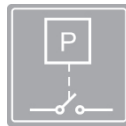

SAFEMATIC S SAFEMATIC W

OPERATING CHARACTERISTICS

- Dry-running protection without configuration.
- Overload protection.
- ART function (Automatic Reset Test). If the device has been stopped due to the action of the safety system against dry operation, the ART tries to connect the pump, with a programmed periodicity because the water supply could have been restored.
- Rapid-cycle alarm: when the hydropneumatic tank has lost the air and frequent start-stops are produced an alarm is activated.
- Manual start push-button.
- Failure, power and pump on led-lights.
- Integrated Schuko socket for the pump connection.
- 2 possible connections to the power supplier:
 - Integrated Schuko plug.
 - Cable with plugs type G or B in wall mounted applications.
- RoHS and WEEE compliant.
- EMC certified and Electrical Safety certified.

USERS INTERFACE

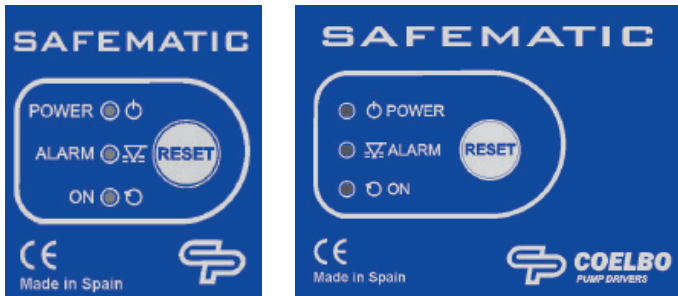

- POWER light (Green)
 - Bright: "OVERLOAD"
 - Slow flashing: "ART MODE"
 - Fast flashing: "DRY RUN"
- Alarm light (red)
 - Bright: "PUMP ON"
 - Slow flashing: "LEARNING"
 - Fast flashing: "FAST CYCLE WARNING"
- Led ON (yellow)
- RESET push-button.

TECHNICAL CHARACTERISTICS

	SAFEMATIC
Power	0,37- 2,2 kW
Voltage	~1 x 115-230 Vac
Frequency	50/60 Hz
Maximum current	30(16) A
Protection degree	IP65 (IP44)
Max environment temperature	50 °C
Net weight (without cable)	0,4 kg

DIMENSIONS AND INSTALLATION

Schuko integrated

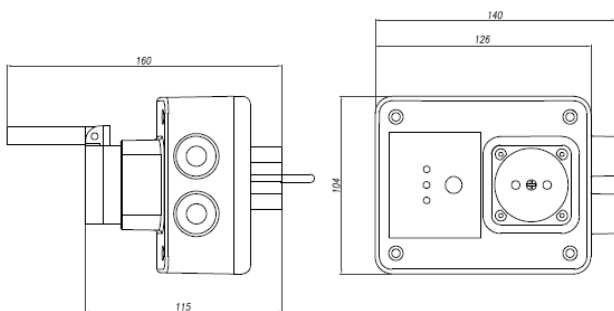

Wall Style

