

BEST BOX

LIFT STATIONS

Garage, Wash basin, Shower

Strong prefabricated lift stations.

APPLICATIONS

- **Best Box G (Garage Model)**
Lifting rainwater, from washing areas, garage ramps etc.
- **Best Box L (Wash basin Model)**
Lifting water for domestic and bathroom use, (sink, dishwasher, washing machine)
- **Best Box D (Shower Model)**
Especially suitable for shower water, does not have to be buried thanks to the tank inlet positioned at 90 mm from the bottom and a non-return device

TECHNICAL DETAILS

- Easy and quick installation
- Strong and compact construction
- Version available with or without electric pump

TECHNICAL DATA

Reservoir

- Model G (Garage): High resistance PVC grill
- Model L (Wash basin): cover with overflow vent
- Model D (Shower): cover with overflow vent
- Reservoir capacity: 30 litres
- Reservoir weight: 7 kg (BEST BOX L and BEST BOX D), 10 kg (BEST BOX G)

Electric pump (in models prepared)

- The BEST BOX G model can be equipped with BEST ONE VOX electric pump (vortex impeller) equipped with float for automatic functioning
- The BEST BOX L and BEST BOX D models can be set-up with the BEST ONE electric pump, equipped with float for automatic functioning. The BEST BOX L model is set-up to receive waters from above, while the BEST BOX D model is set-up to receive waters from below
- 5 metres of cable + standard socket
- 2800 min-1
- Single-phase voltage: 230V +/- 10%
- Class of insulation F
- IP68 Protection rating
- Maximum temperature of the liquid pumped: 50°C
- Max. solids size for passage: 10 mm BEST ONE
20 mm BEST ONE VOX

MATERIALS

Reservoir

- High density polyethylene

Electric pump (in models prepared)

- Completely in AISI 304 stainless steel
- Equipped with mechanical seal as per standard

For technical data regarding BEST ONE/ BEST ONE VOX electric pumps (see page 7)



BEST BOX G



BEST ONE VOX



BEST BOX D



BEST ONE

PERFORMANCE CURVES (according to ISO 9906 Attachment A)

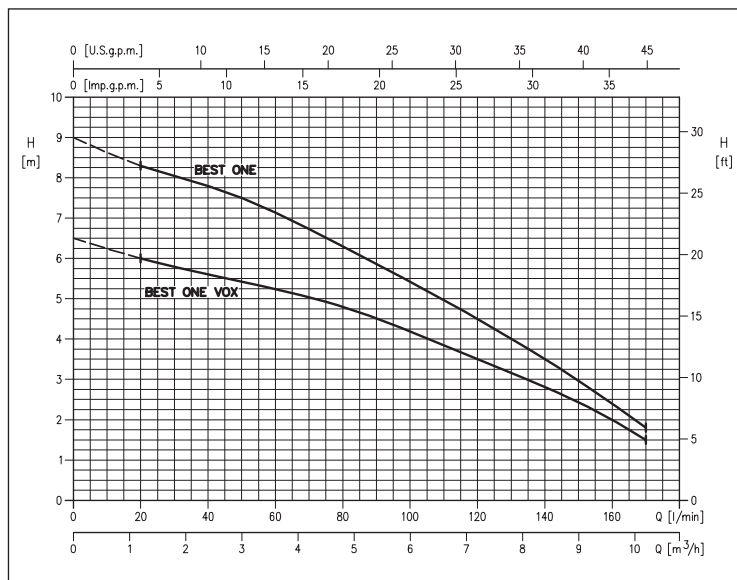

BEST BOX

LIFT STATIONS

Garage, Wash basin, Shower

BEST BOX G DIMENSIONS

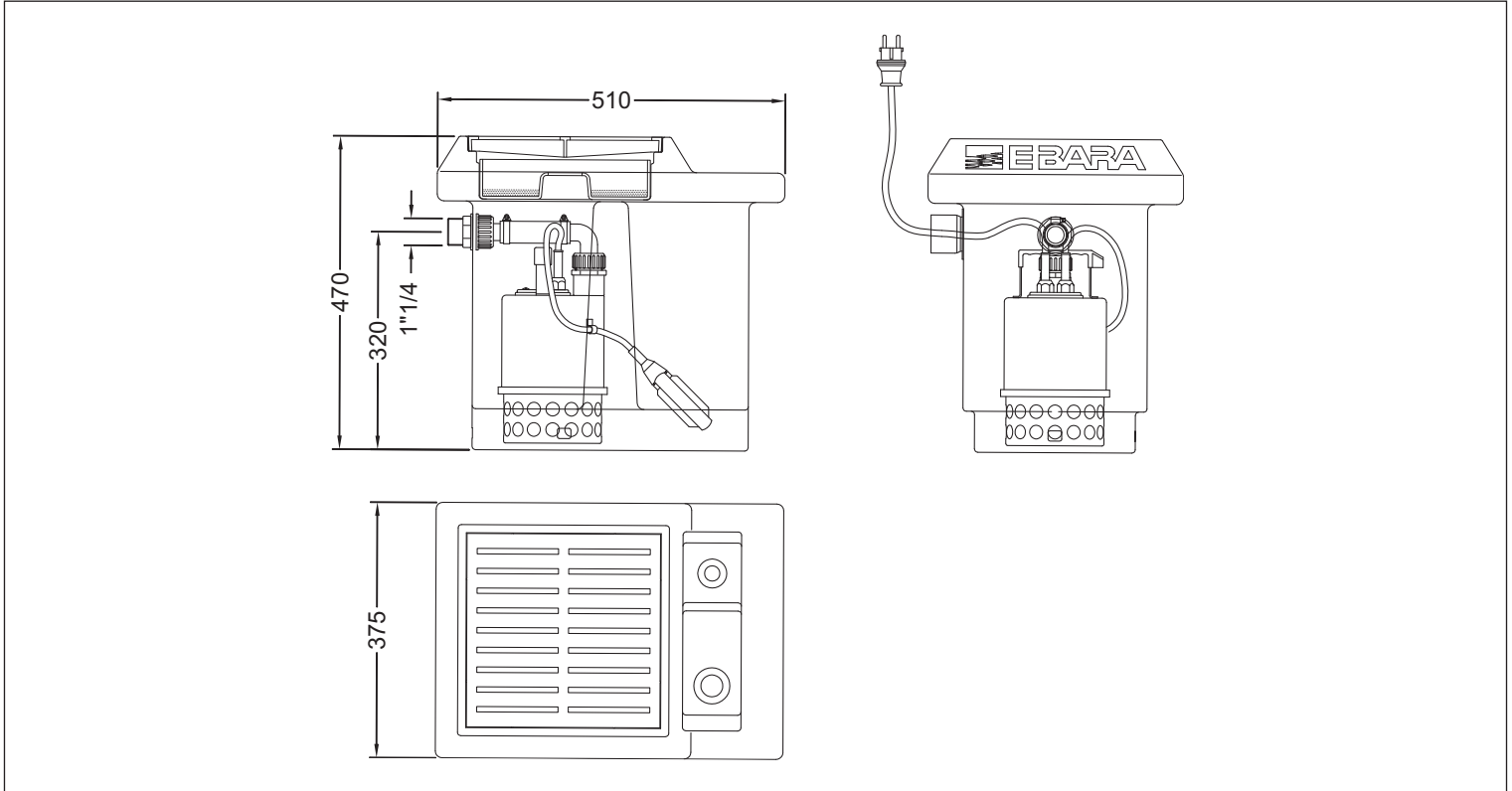

BEST BOX L DIMENSIONS

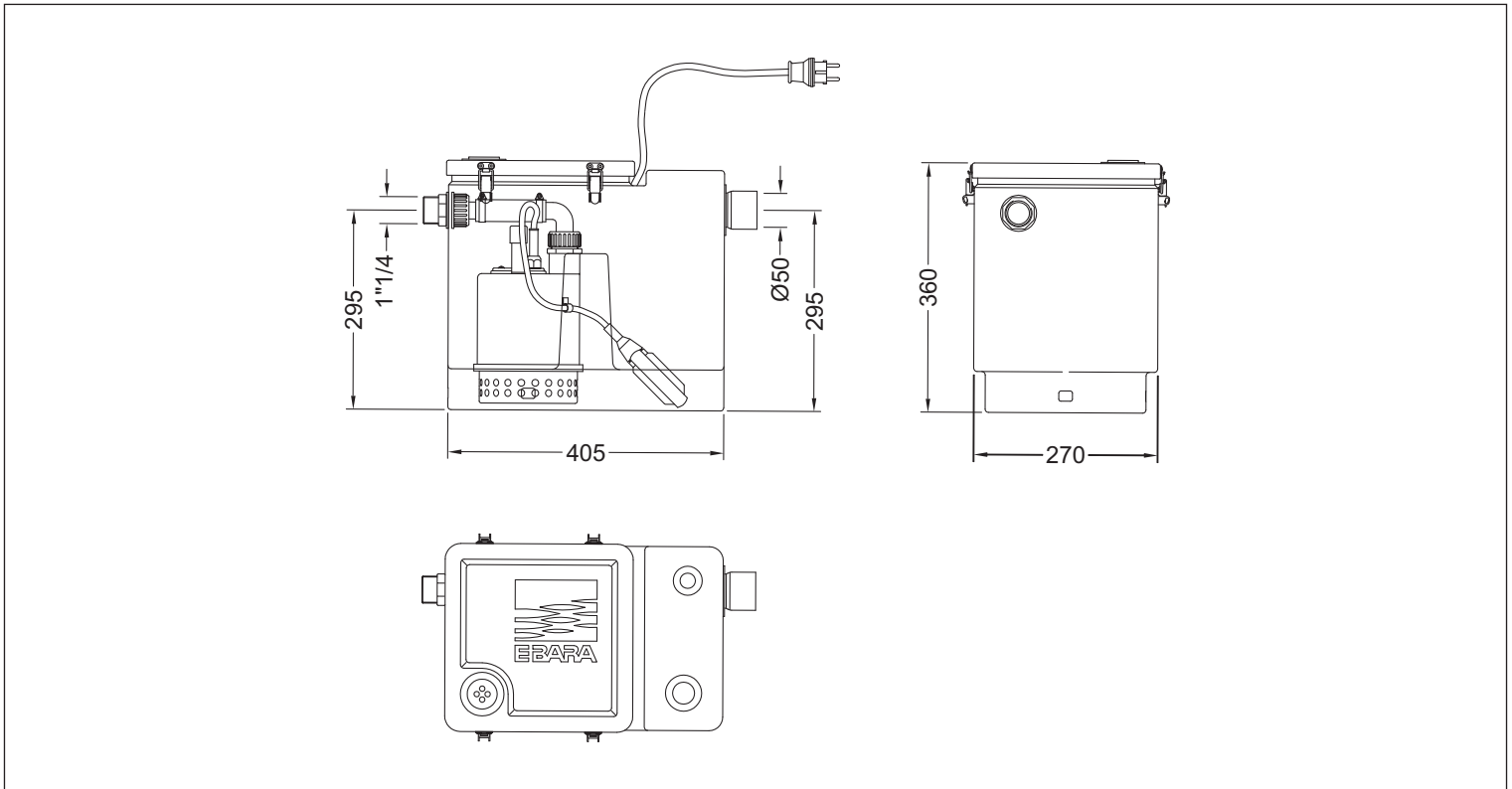

LIFT STATIONS

Garage, Wash basin, Shower

BEST BOX G DIMENSIONS

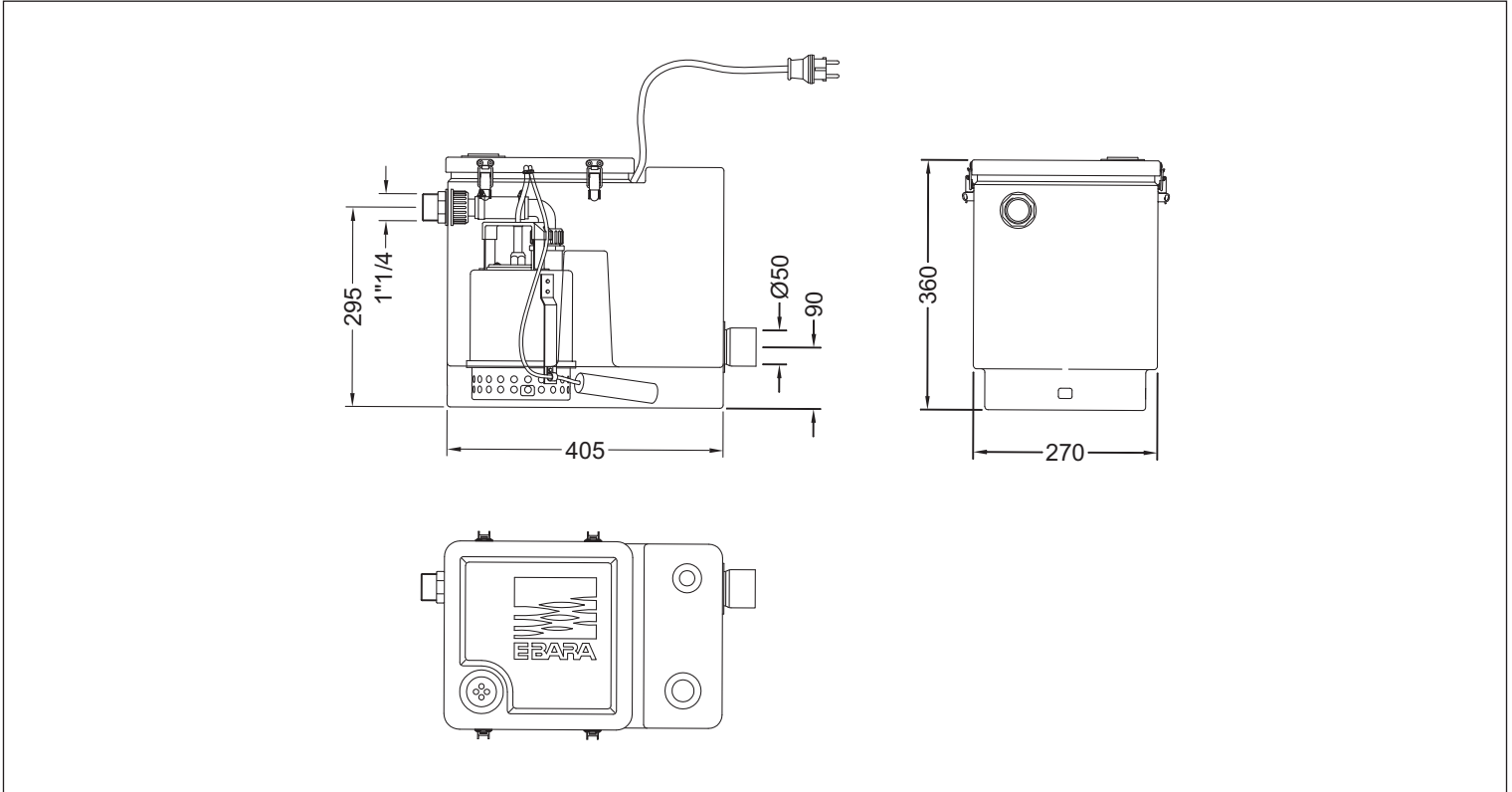

INSTALLATION

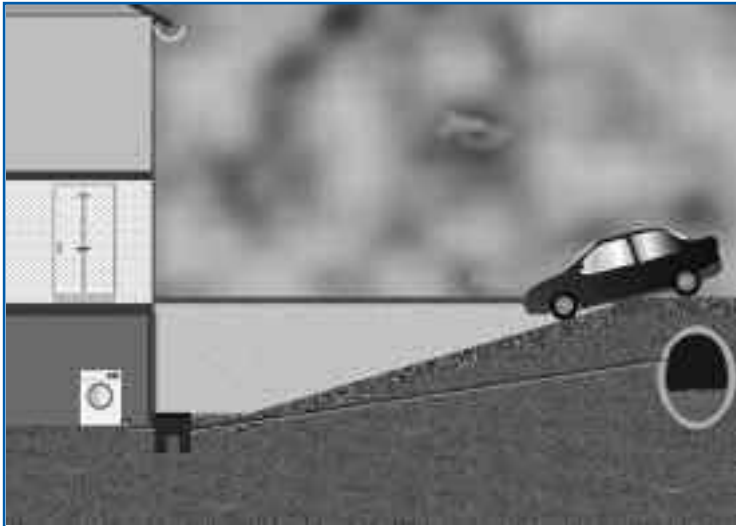

BEST BOX Garage is destined to be buried in the lowering arrival point of a garage.

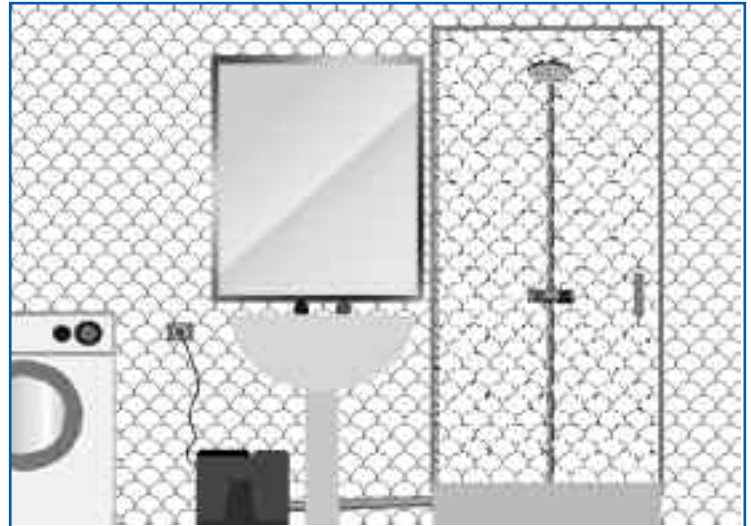

System excludes low level cutout, in shower model.

BEST BOX

LIFT STATIONS

Garage, Wash basin, Shower

TECHNICAL SPECIFICATIONS

