

## Self-priming close-coupled pumps

for pure and contaminated liquids

### Fields of application

- Water supply
- Fire-fighting systems
- Spray irrigation
- Irrigation
- Drainage
- Air-conditioning systems
- Drinking water
- Industrial water
- Cooling water
- Swimming pool water
- Seawater
- Fire-fighting water
- Brackish water
- Condensate
- Brine
- Oils
- Cleaning agents

### Operating data

	50 Hz	60 Hz
Q	up to 100 m <sup>3</sup> /h (28 l/s)	up to 120 m <sup>3</sup> /h (33 l/s)
H	up to 85 m	up to 90 m
p <sub>2</sub>	up to 10 bar <sup>1)</sup>	up to 10 bar <sup>1)</sup>
H <sub>1geo</sub>	up to 9 m	up to 9 m
t	-30 to +90 °C	-30 to +90 °C

1) see pressure limits, page 6

### Design

Horizontal volute casing pumps, single-stage, with open multi-vane impeller.

On pump sizes 40-140 and above, the shaft is fitted with a replaceable shaft sleeve in the shaft seal area.

#### Etaprime BN

Pump and motor flanged together to form a close-coupled unit, with standardized motor to DIN 42 677.

Pump shaft and motor shaft are rigidly connected.

Pump connections to DIN/EN or ASME.

#### Etaprime B

Pump and motor flanged together to form a close-coupled unit, with common shaft

### Shaft seal

Single-acting mechanical seal to EN 12 756.

On Etaprime BN, double-acting mechanical seals are possible.

### Certification

Certified quality management ISO 9001.

### Designation

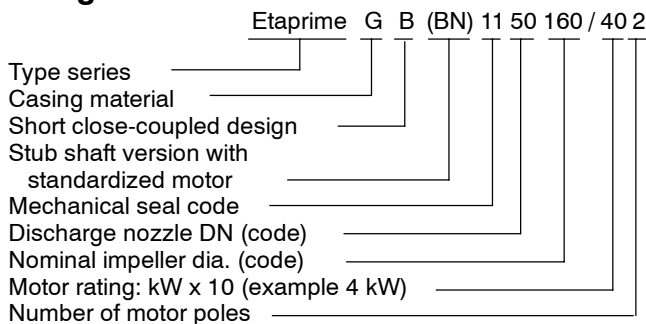

### Drive

#### Standard version Etaprime BN

Surface-cooled KSB-IEC three-phase squirrel cage motor

Winding 50 Hz: up to 2.2 kW 220-240/380-420 V,  
4 kW and above: 380-420 /660-725 V,

Winding 60 Hz: 440-480 V,  
Design: 1.1 kW IM B34 <sup>1)</sup>

up to 4 kW IM V1

7.5 kW and above IM V15

Enclosure: IP 55

Thermal class: F with temperature sensors:  
3 PTC thermistors

Operating mode: continuous operation S1  
or

surface-cooled three-phase squirrel cage motor as described above, but West European brand to KSB's choice

1) without temperature sensors, with flange C-120

#### Standard version Etaprime B

Surface-cooled KSB three-phase squirrel cage motor with longer shaft and special flange

Winding: up to 2.2 kW, 230/400 V

4 kW: 400/690 V

Design: IM B5

Enclosure: IP 55 or IP 54

Thermal class: F

Operating mode: continuous operation S1

**Contact guard:** cover plates on drive lantern to EN 294

n = 1.450 1/min

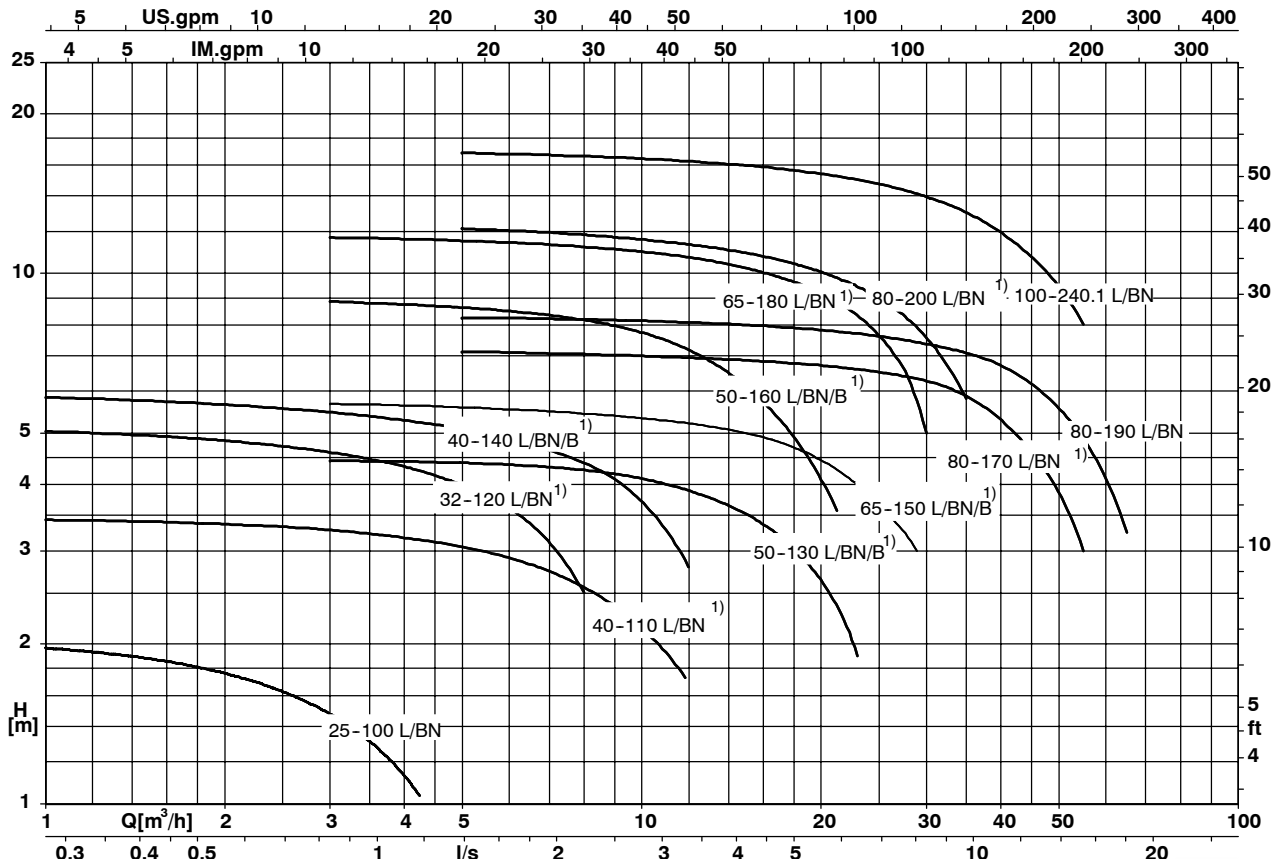

- 1) lieferbar auch in Chrom-Nickel-Molybdänstahlguss  
 1) also available in cast CrNiMo steel  
 1) Egalement disponible en acier moulé au CrNiMo
- 1) Suministrable también en Acero moldeado al Cr-Ni-Mo  
 1) Ook leverbaar in chroom-nikkel-molybdeenstaal  
 1) Disponibile anche come fusione di acciaio al cromo-nichel-molibdeno

EP1450.01

n = 2.900 1/min

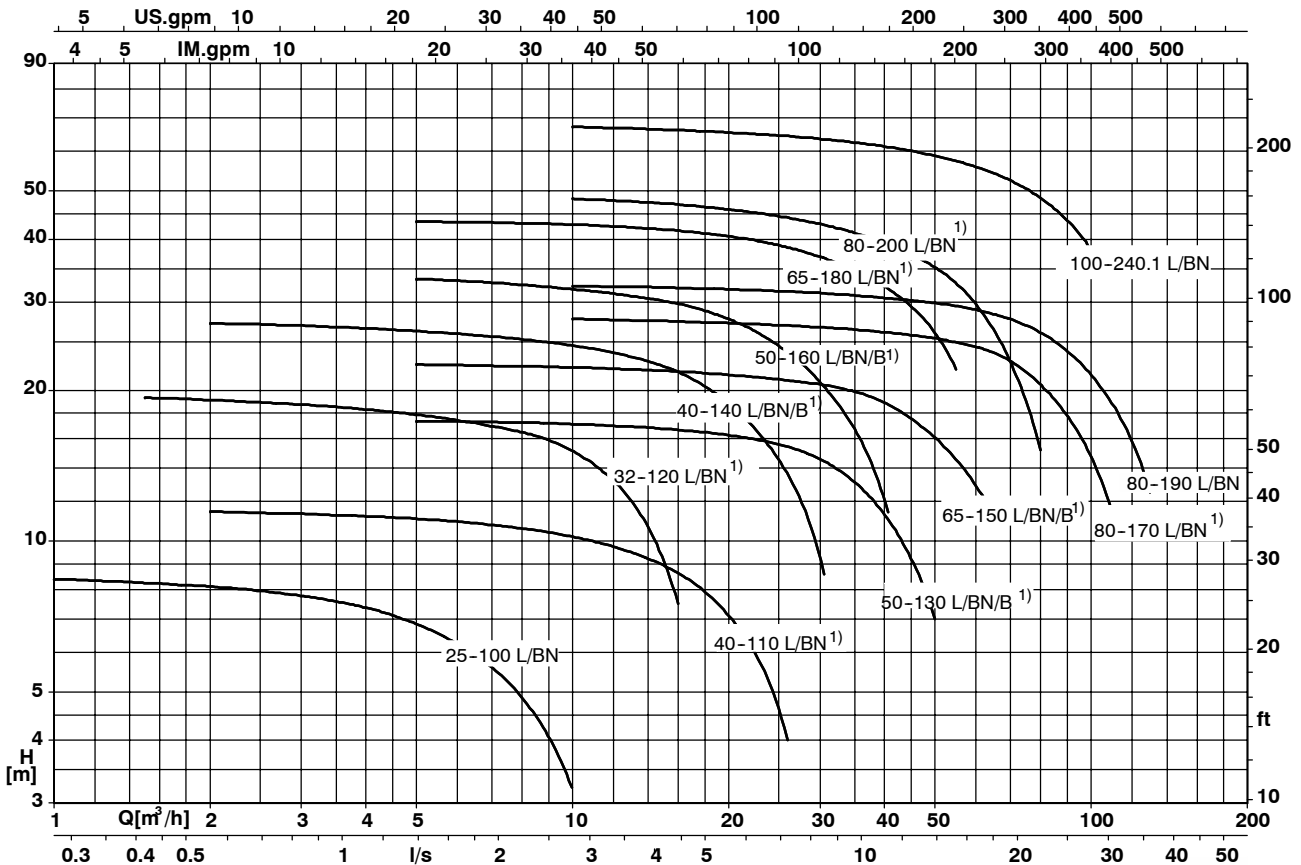

- 1) lieferbar auch in Chrom-Nickel-Molybdänstahlguss  
 1) also available in cast CrNiMo steel  
 1) Egalement disponible en acier moulé au CrNiMo
- 1) Suministrable también en Acero moldeado al Cr-Ni-Mo  
 1) Ook leverbaar in chroom-nikkel-molybdeenstaal  
 1) Disponibile anche come fusione di acciaio al cromo-nichel-molibdeno

EP2900.01

n = 1.750 1/min

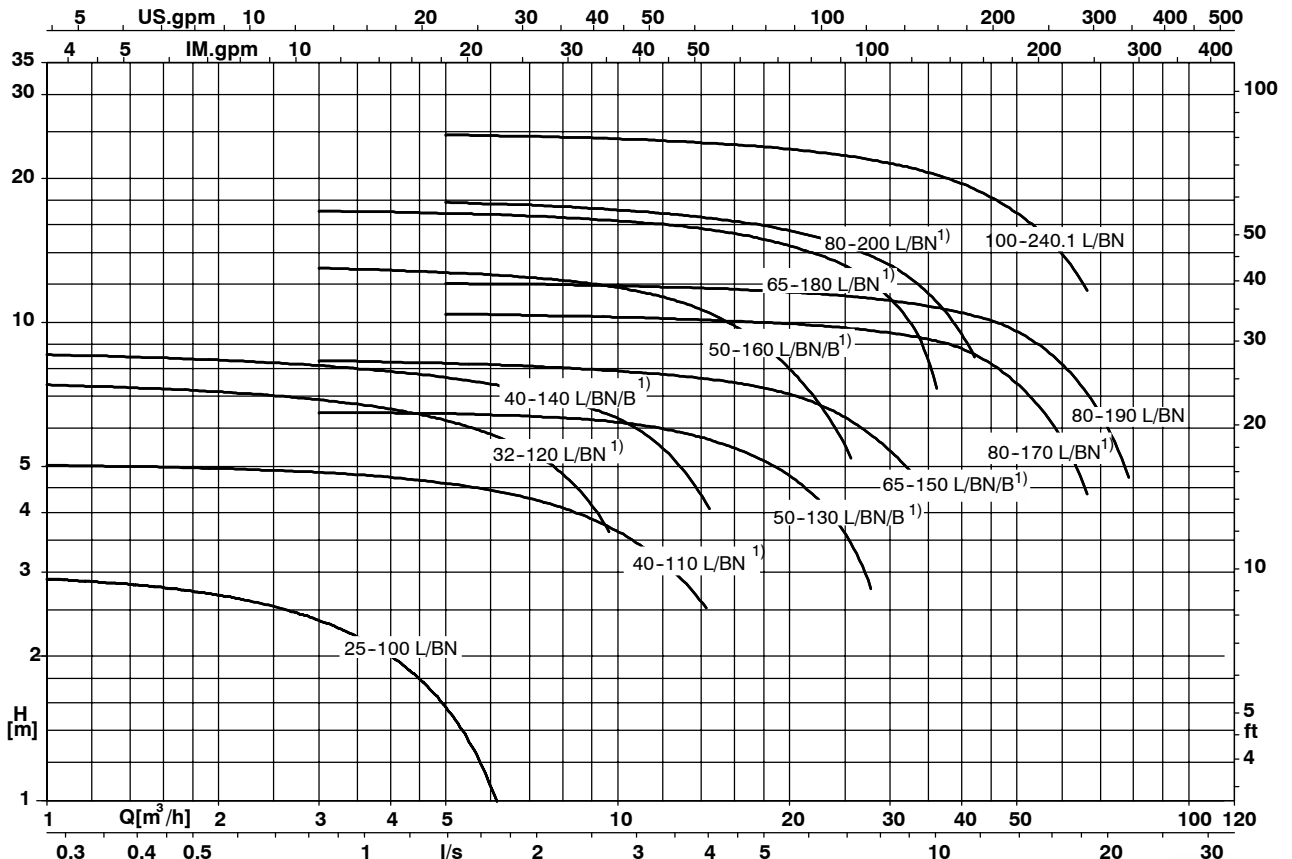

1) lieferbar auch in Chrom-Nickel-Molybdänstahlguss 1) Suministrable también en Acero moldeado al Cr-Ni-Mo  
 1) also available in cast CrNiMo steel 1) Ook leverbaar in chroom-nikkel-molybdeenstaal  
 1) Egalement disponible en acier moulé au CrNiMo 1) Disponibile anche come fusione di acciaio al cromo-nichel-molibdeno

EP1750.01

n = 3.500 1/min

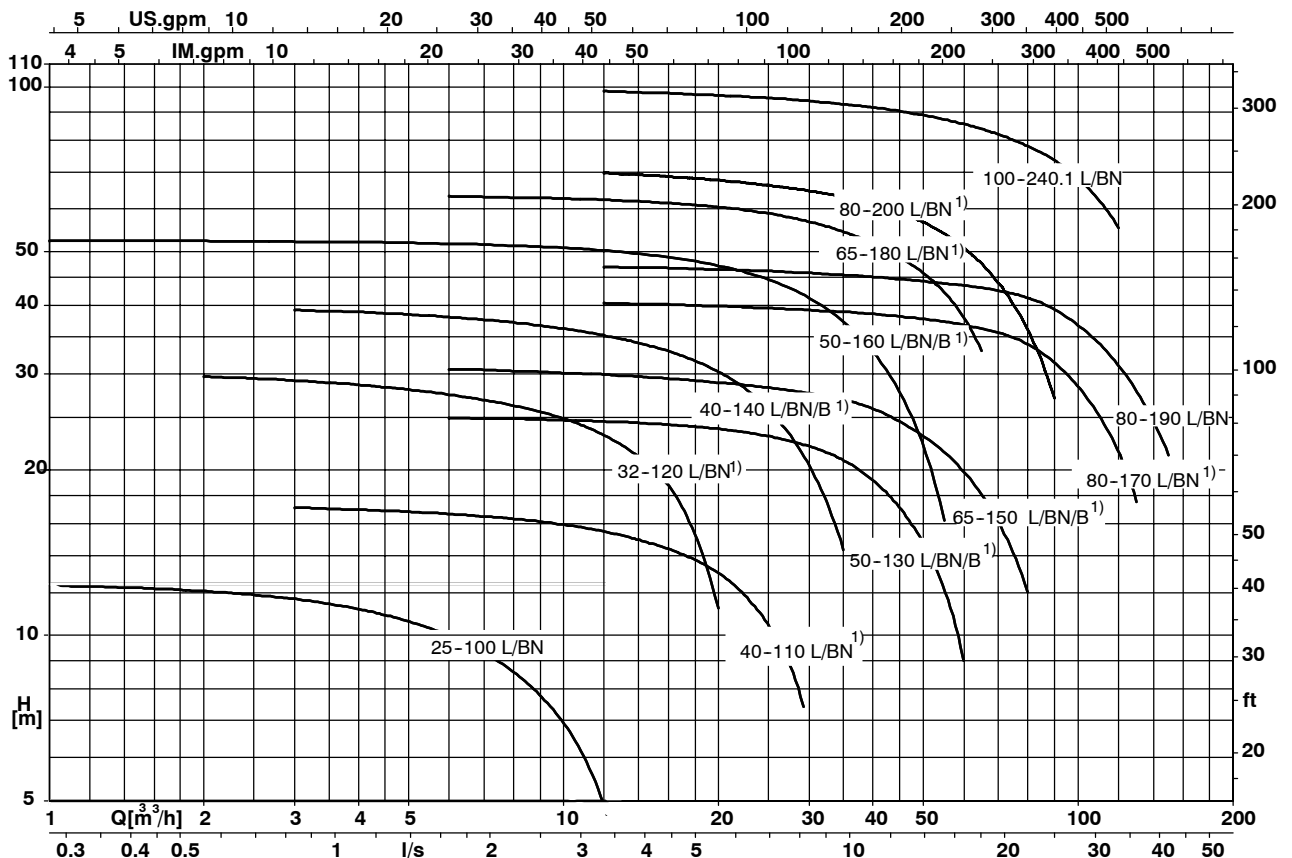

1) lieferbar auch in Chrom-Nickel-Molybdänstahlguss 1) Suministrable también en Acero moldeado al Cr-Ni-Mo  
 1) also available in cast CrNiMo steel 1) Ook leverbaar in chroom-nikkel-molybdeenstaal  
 1) Egalement disponible en acier moulé au CrNiMo 1) Disponibile anche come fusione di acciaio al cromo-nichel-molibdeno

EP3500.01

**Product Advantages at a Glance**

**Etaprime BN**

Self-priming after the pump casing has been filled with the fluid handled.

Excellent suction behaviour, self-priming up to 9 m; no foot valve required.

Unit is insensitive to the penetration of gas and air.

Double-acting mechanical seal available for tough applications

Service-friendly, sturdy KSB IEC three phase motor

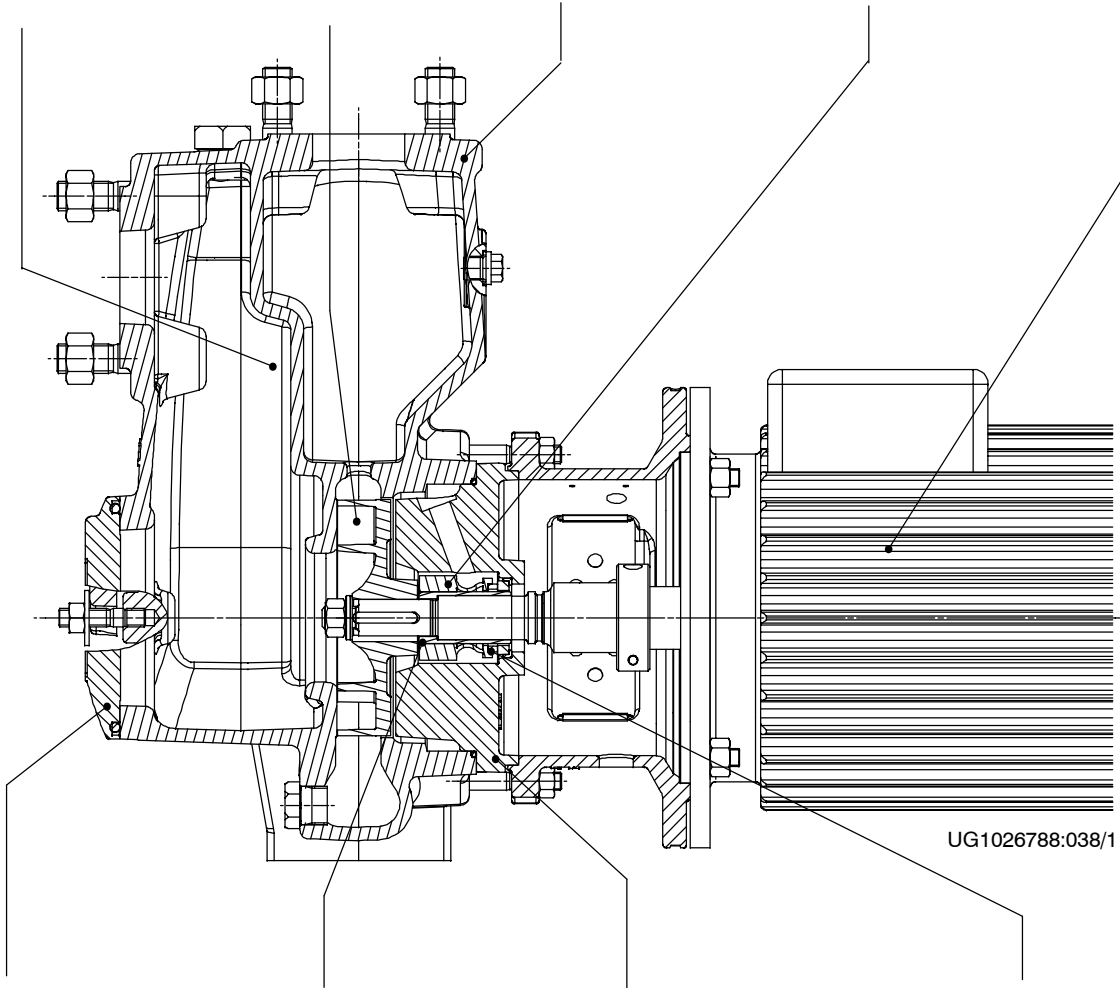

Inspection cover for easy cleaning.

Shaft sleeve prevents wear on the shaft.

Back pull-out design: the casing may remain in the pipeline when the pump is dismantled.

Reliable, maintenance-free mechanical seal.

## Overview of Type Series

Sizes and types available

Pump size	Shaft unit	ETAPRIME L		ETAPRIME BN		ETAPRIME B	
		GL JL 1040	CL 1.4408	GBN JL 1040	CBN 1.4408	GB JL 1040	
25-100	17	E/T	o	E/T	o	o	o
32-120		E/T	E/T	E/T	E/T	o	o
40-110		E/T	E/T	E/T	E/T	o	o
40-140	25	E/T/B	E/T/B	E/T/B	E/T/B	E	o
50-130		E/T/B	E/T/B	E/T/B	E/T/B	E	o
50-160		E/T/B	E/T/B	E/T/B	E/T/B	E	o
65-150		E/T/B	E/T/B	E/T/B	E/T/B	E	o
65-180	35	E/T/B	E/T/B	E/T/B	E/T/B	o	o
80-170		E/T/B	E/T/B	E/T/B	E/T/B	o	o
80-190		E/T/B	o	E/T/B	o	o	o
80-200		E/T/B	E/T/B	E/T/B	E/T/B	o	o
100-240.1		E/T/B	o	E/T/B	o	o	o

- = available size  
 o = size not available  
 E = single-acting mechanical seal (standard design)  
 T = double-acting mechanical seal in TANDEM arrangement possible  
 B = double-acting mechanical seal in BACK-to-BACK arrangement possible

## Materials

Description	Etaprime GB, GBN	Etaprime CB, CBN
Volute casing	Grey cast iron JL 1040 <sup>4)</sup>	Cast chrome nickel molybdenum steel 1.4408
Casing cover	Grey cast iron JL 1040 <sup>4)</sup>	Cast chrome nickel molybdenum steel 1.4408
Shaft	Tempering steel C45+N <sup>3)</sup>	Chrome nickel molybdenum steel 1.4571
Impeller	Grey cast iron JL 1040 <sup>4)</sup>	Cast chrome nickel molybdenum steel 1.4408
Drive lantern <sup>2)</sup>	Grey cast iron JL 1040 <sup>4)</sup>	Grey cast iron <sup>5)</sup> JL 1040 <sup>4)</sup>
Shaft sleeve <sup>1)</sup>	Chrome nickel molybdenum steel 1.4571	Chrome nickel molybdenum steel 1.4571

- 1) not fitted on shaft unit 17  
 2) not fitted on Etaprime B  
 3) for shaft unit 17 = Chrome nickel molybdenum steel 1.4571  
 4) to EN 1561 = GJL-250  
 5) for shaft unit 17 = Chrome nickel molybdenum steel 1.4408  
 For shaft unit / pump size combinations see Overview of Type Series above

## Flange Connections / Pump connections

Pump size	Shaft unit	Standard connection	Special connection
25-100	17	Pipe thread	Pipe thread
32-120		Rp to ISO 7/1	NPT to ASME B1.20.1
40-110			
40-140	25	Flange to EN 1092-2, PN16, (JL 1040) to EN 1092-1, PN16, (1.4408)	Flange to ASME BE 16.1 Class 125 (to ZN 2606)
50-130			
50-160			
65-150			
65-180	35	Flange to EN 1092-2, PN16, (JL 1040) to EN 1092-1, PN16, (1.4408)	Flange to ASME BE 16.1 Class 125 (to ZN 2606)
80-170			
80-190			
80-200			
100-240.1			

**Pressure limits**

Pump size	Dis-charge pressure $p_2^{1)}$ (bar)	Test pressure $p_2^2)$ (bar)	Pump size	Dis-charge pressure $p_2^{1)}$ (bar)	Test pressure $p_2^2)$ (bar)
25-100	10.0	15.0	65-150	10.0	15.0
32-120	10.0	15.0	65-180	10.0	15.0
40-110	10.0	15.0	80-170	10.0	15.0
40-140	10.0	15.0	80-190	10.0	15.0
50-130	10.0	15.0	80-200	10.0	15.0
50-160	10.0	15.0	100-240.1	10.0	15.0

- 1) The sum of inlet pressure and head at zero flow point must not exceed the values indicated.
- 2) The casing components are checked for leakage by means of internal pressure tests to AN 1897/75-03 with water.

**Priming Time**

with a horizontal length of the suction line of 1 m and suction line  $D_N = \text{pump } D_N$

ETAPRIME B / BN	Suction time [ sec ] for speed $n = 2,900/3,500$ rpm at a static suction lift $H_{1\text{geo}}$ of ... m				
	2 m	4 m	5 m	7 m	8 m
25-100	50	135	240	-	-
32-120	30	90	120	255	360
40-110	60	135	180	300	360
40-140	30	80	100	210	300
50-130	50	120	150	245	300
50-160	30	60	90	180	240
65-150	60	150	180	300	360
65-180	30	50	80	150	210
80-170	50	120	180	300	360
80-190	50	65	90	150	180
80-200	30	60	80	195	180
100-240.1	30	50	60	90	-

ETAPRIME B / BN	Suction time [ sec ] for speed $n = 1,450/1,750$ rpm at a static suction lift $H_{1\text{geo}}$ of ... m					
	1 m	2 m	4 m	5 m	7 m	8 m
25-100	120	-	-	-	-	-
32-120	150	200	-	-	-	-
40-110	140	-	-	-	-	-
40-140	120	240	-	-	-	-
50-130	200	360	-	-	-	-
50-160	180	320	-	-	-	-
65-150	180	360	-	-	-	-
65-180	160	180	360	-	-	-
80-170	150	240	420	-	-	-
80-190	120	160	300	-	-	-
80-200	80	120	240	300	-	-
100-240.1	100	140	280	400	-	-

The above data refers to water at 20 °C.

**Caution** When handling fluids which liberate gas or tend to froth, **the pump will not be self-priming**. In such cases, a check valve should be installed in the suction line.

**Electrical connection values**

Pump size	Motor code	IEC size	50 Hz [kW]	60 Hz [kW]	50 Hz / 60 Hz ~ 400 V [A]
alle	.../ 054	80	0.6	0.6	1.4
	.../ 154	90L	1.5	1.7	3.4
	.../ 224	100L	2.2	2.5	4.9
	.../ 304	100L	3.0	3.4	6.3
	.../ 404	112M	4.0	4.6	8.3
	.../ 112	80	1.1	1.3	2.6
	.../ 222	90L	2.2	2.5	4.6
	.../ 302	100L	3.0	3.4	6.3
	.../ 402	112M	4.0	4.6	8.3
	.../ 552	132S	5.5	6.3	11.0
	.../ 752	132S	7.5	8.6	14.6
	.../ 1102	160M	11.0	12.6	20.7
	.../ 1502	160M	15.0	17.3	28.0
	.../ 1852	160L	18.5	21.3	33.0
	.../ 2202	180M	22.0	24.5	40.0
	.../ 3002	200L	30.0	34.5	54.0

- 1) The above values for current in A are for orientation only. For exact current values please refer to the motor nameplate.

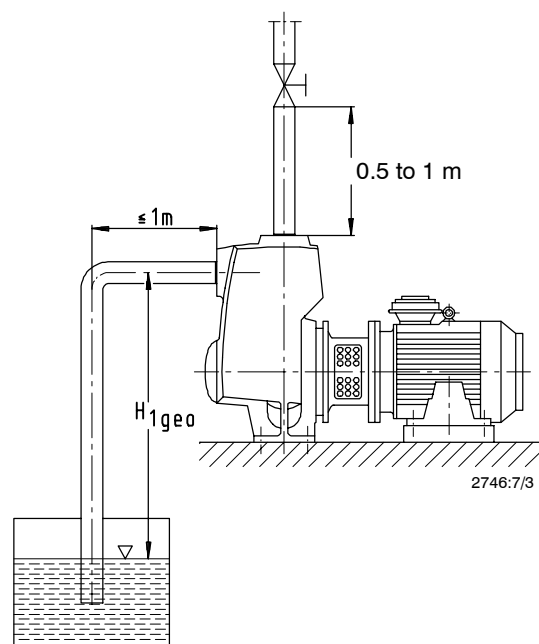

Fluid handled	Application limits	Materials		Shaft seal				Reference code	Comments
		Casing/Impeller		Mechanical seal					
		Grey cast iron/ Grey cast iron	Cast CrNiMo steel/ Cast CrNiMo steel	AC1VGG 2)	U3U3VGG	Q1Q1X4GG	B01EGG 2)		
G	C	8	9	10	11				
<b>Water</b>									
Ammonia water (salmiac)	t ≤ 40 °C; conc. ≤ 10%	X					X	GB11, GBN11	
Brackish water	t ≤ 25°C		X			X		CB10, CBN10	
Condensate <sup>2)</sup>	t ≤ 90°C	X					X	GB11, GBN11	
Condensate, non-conditioned	t ≤ 90°C		X				X	CBN11	
Cooling water (no anti-freeze) <sup>1)</sup>	t ≤ 60°C	X				X		GB10, GBN10	open circuit: CBN10 required
Cooling water pH value ≥ 7.5 (with anti-freeze) <sup>1) 3)</sup>	t ≥ -30°C p ≤ 10 bar t ≤ 90°C	X					X	GB11, GBN11	open circuit: CBN11 required
Dam water <sup>1)</sup>	t ≤ 60°C	X				X		GB10, GBN10	if solids - laden: contact KSB
Drinking water <sup>1)</sup>	t ≤ 60°C	X					X	GB11, GBN11	
Fire-fighting water <sup>1)</sup>	t ≤ 60°C	X				X		GB10, GBN10	
Fully desalinated water	t ≤ 90°C		X				X	CBN11	Requirements for ultra-pure water cannot be met.
Fully desalinated water as boiler feed water <sup>2)</sup>	t ≤ 90°C	X					X	GB11, GBN11	
Partly desalinated water <sup>2)</sup>	t ≤ 90°C	X					X	GB11, GBN11	
Pure water <sup>4)</sup>	t ≤ 60°C	X					X	GB11, GBN11	
Seawater	t ≤ 25°C		X			X		CBN10	
Slightly contaminated water <sup>1)</sup>	t ≤ 60°C	X				X		GB10, GBN10	
Surface water <sup>1)</sup>	t ≤ 40°C	X		X				GB 8, GBN 8	Analysis of fluid handled required.
Swimming-pool water <sup>1)</sup> (fresh water)	t ≤ 60°C	X				X		GB10, GBN10	Also for requirements to DIN 19 643
Untreated water <sup>1)</sup>	t ≤ 60°C	X				X		GB10, GBN10	
Waste water (industrial)									Analysis of fluid handled required.
<b>Refrigerants, cooling brines</b>									
Cooling brine, inorganic, pH value > 7.5; inhibited	t ≥ -30°C t ≤ 25°C	X					X	GB11, GBN11	
Water with anti-freeze, pH value ≥ 7.5 <sup>1) 3)</sup>	t ≥ -30°C; t ≤ 90°C	X					X	GB11, GBN11	
<b>Oils/Emulsions</b>									
Drilling/Grinding emulsion	t ≤ 60°C	X			X			GB 9, GBN 9	
Oil-water emulsion	t ≤ 60°C	X			X			GB 9, GBN 9	
<b>Cleaning agents</b>									
Bottle rinsing lyes	t ≤ 90°C	X				X		GB10, GBN10	
<b>Acids</b>									
Acetic acid	t ≤ 60 °C; conc. ≤ 5% t ≤ 60 °C; conc. ≤ 10%		X				X	CBN11	

- 1) General criteria for results of water analysis: pH value ≥ 7; chloride (Cl) content ≤ 150 mg/kg. Chlorine (Cl<sub>2</sub>) ≤ 0.6 mg/kg. Ammonia (NH<sub>3</sub>) ≤ 5mg/kg, free from hydrogen sulphide (H<sub>2</sub>S); no limitation of Cl content required in this case.
- 2) Treatment to VdTUV 1466; additional requirement : O<sub>2</sub> ≤ 0.02 mg/l.
- 3) Antifreeze on ethylene glycol basis with inhibitors. Content: 20 % to 50 % (e.g. Antifrogen N)
- 4) No ultra-pure water! Conductivity at 25 °C: ≤ 800 µS/cm.

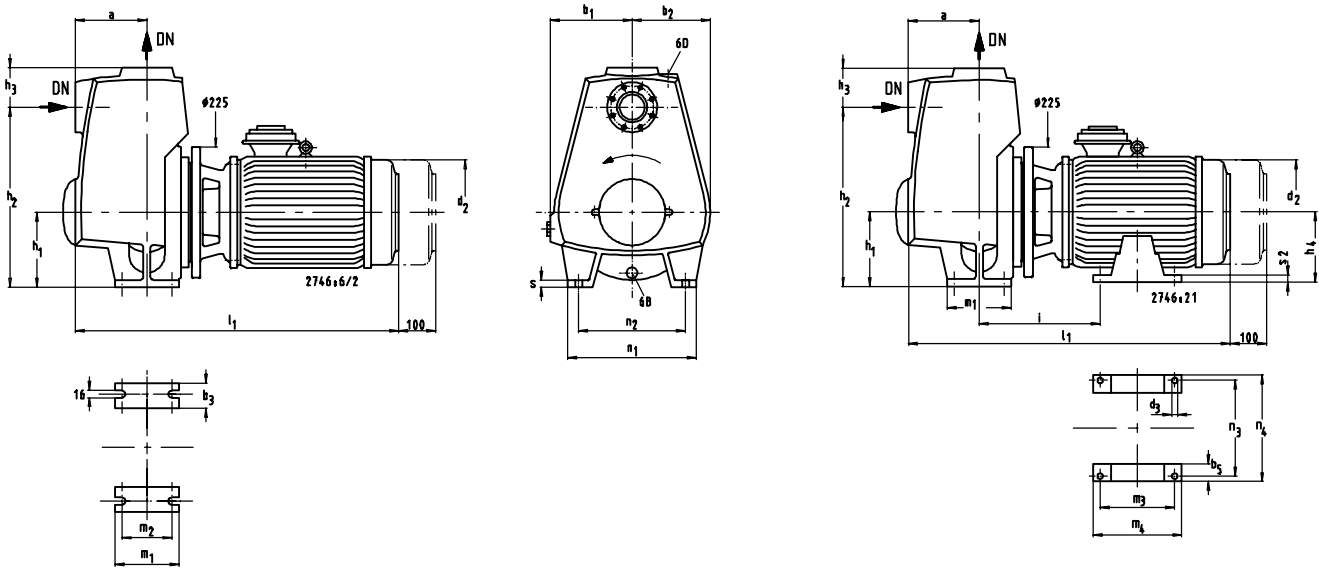
**Etapprime B 40-140/... - 65-150/...  
with motor foot from motor size 132 = 5.5 kW**

Etapprime B	6 B <sup>1)</sup>	6 D <sup>1)</sup>	
40-140/...	R <sub>c</sub> 3/8	R <sub>c</sub> 3/4	6 B Förderflüssigkeit-Entleerung / Casing drain / Vidange du liquide véhiculé / Scarico del liquido convogliato / Vaciado del líquido de impulsión / attap. pomphuis  6 D Förderflüssigkeit-Auffüllen und Entlüften / Fluid handled-priming and venting / Remplissage et dégazage de liquide véhiculé / Riempimento e scarico del liquido convogliato / Llenado y desaireación del líquido de impulsión / vul en ontlichting
50-130/...	R <sub>c</sub> 1/2	R <sub>c</sub> 3/4	
50-160/...	R <sub>c</sub> 1/2	R <sub>c</sub> 3/4	
65-150/...	R <sub>c</sub> 1/2	R <sub>c</sub> 3/4	

 1) R<sub>c</sub> = ISO 7/1

Flange dimensions						mm	
Flange connection	DN	Dia. of bolt circle	z	d	l <sub>1</sub>		
Standard EN 1092-1 EN 1092-2	40	110	4	M 16	40		
	50	125					
	65	145					
	80	160					
Special ASME BE 16.1 Class 125 (ZN 2606)	40	98.6	4	UNC 1/2-13	40		
	50	120.7					
	65	139.7					
	80	152.4					
	100	180	8		45		
	100	190.5	8		45		

Tolerances of connecting dimensions as per EN 735

mm

Etapprime B	n = 1.450 1/min	n = 1.750 1/min	n = 2.900 1/min	n = 3.500 1/min	DN	a	b <sub>1</sub>	b <sub>2</sub>	b <sub>3</sub>	b <sub>5</sub>	d <sub>2</sub>	d <sub>3</sub>	h <sub>1</sub>	h <sub>2</sub>	h <sub>3</sub>	h <sub>4</sub>	i	l <sub>1ca</sub>	m <sub>1</sub>	m <sub>2</sub>	m <sub>3</sub>	m <sub>4</sub>	n <sub>1</sub>	n <sub>2</sub>	n <sub>3</sub>	n <sub>4</sub>	s <sub>1</sub>	s <sub>2</sub>	
																													X
40-140 / 054 / 154 / 222 / 302 / 402 / 552 <sup>2)</sup>	X				40	115	128	115	57	-	170	-	112	284	73	-	-	460	100	70	-	-	220	160	-	-	16	-	
		X			40	115	128	115	57	-	190	-	112	284	73	-	-	491	100	70	-	-	220	160	-	-	16	-	
			X		40	115	128	115	57	-	190	-	112	284	73	-	-	491	100	70	-	-	220	160	-	-	16	-	
				X	40	115	128	115	57	-	213	-	112	284	73	-	-	515	100	70	-	-	220	160	-	-	16	-	
					X	40	115	128	115	57	-	234	-	112	284	73	-	-	536	100	70	-	-	220	160	-	-	16	-
					X	40	115	128	115	57	43	266	12	112	284	73	132	202	601	100	70	140	220	220	160	216	270	16	15
50-130 / 054 / 154 / 222 / 302 / 402	X				50	130	138	128	55	-	170	-	132	317	78	-	-	475	100	70	-	-	250	190	-	-	20	-	
		X			50	130	138	128	55	-	190	-	132	317	78	-	-	506	100	70	-	-	250	190	-	-	20	-	
			X		50	130	138	128	55	-	190	-	132	317	78	-	-	506	100	70	-	-	250	190	-	-	20	-	
				X	50	130	138	128	55	-	213	-	132	317	78	-	-	530	100	70	-	-	250	190	-	-	20	-	
					X	50	130	138	128	55	-	234	-	132	317	78	-	-	551	100	70	-	-	250	190	-	-	20	-
					X	50	130	138	128	55	43	266	12	132	327	75	132	202	616	100	70	140	220	250	190	216	270	20	15
50-160 / 054 / 154 / 402 / 552 <sup>1)</sup> / 752 <sup>1)</sup>	X				50	130	145	126	55	-	170	-	132	327	75	-	-	475	100	70	-	-	250	190	-	-	20	-	
		X			50	130	145	126	55	-	190	-	132	327	75	-	-	506	100	70	-	-	250	190	-	-	20	-	
			X		50	130	145	126	55	-	234	-	132	327	75	-	-	551	100	70	-	-	250	190	-	-	20	-	
				X	50	130	145	126	55	43	266	12	132	327	75	132	202	616	100	70	140	220	250	190	216	270	20	15	
					X	50	130	145	126	55	43	266	12	132	327	75	132	202	616	100	70	140	220	250	190	216	270	20	15
					X	50	130	145	126	55	43	266	12	132	327	75	132	202	616	100	70	140	220	250	190	216	270	20	15
65-150 / 054 / 154 / 402 / 552 <sup>1)2)</sup> / 752 <sup>1)2)</sup>	X				65	140	155	149	55	-	170	-	160	370	85	-	-	485	125	95	-	-	270	212	-	-	23	-	
		X			65	140	155	149	55	-	190	-	160	370	85	-	-	516	125	95	-	-	270	212	-	-	23	-	
			X		65	140	155	149	55	-	234	-	160	370	85	-	-	561	125	95	-	-	270	212	-	-	23	-	
				X	65	140	155	149	55	43	266	12	160	370	85	132	202	626	125	95	140	220	270	212	216	270	23	15	
					X	65	140	155	149	55	43	266	12	160	370	85	132	202	626	125	95	140	220	270	212	216	270	23	15
					X	65	140	155	149	55	43	266	12	160	370	85	132	202	626	125	95	140	220	270	212	216	270	23	15

 1)  $\Delta h_1 \geq h_4$ 

2) For these motor sizes, shims etc. will have to be fitted under the motor/pump feet.

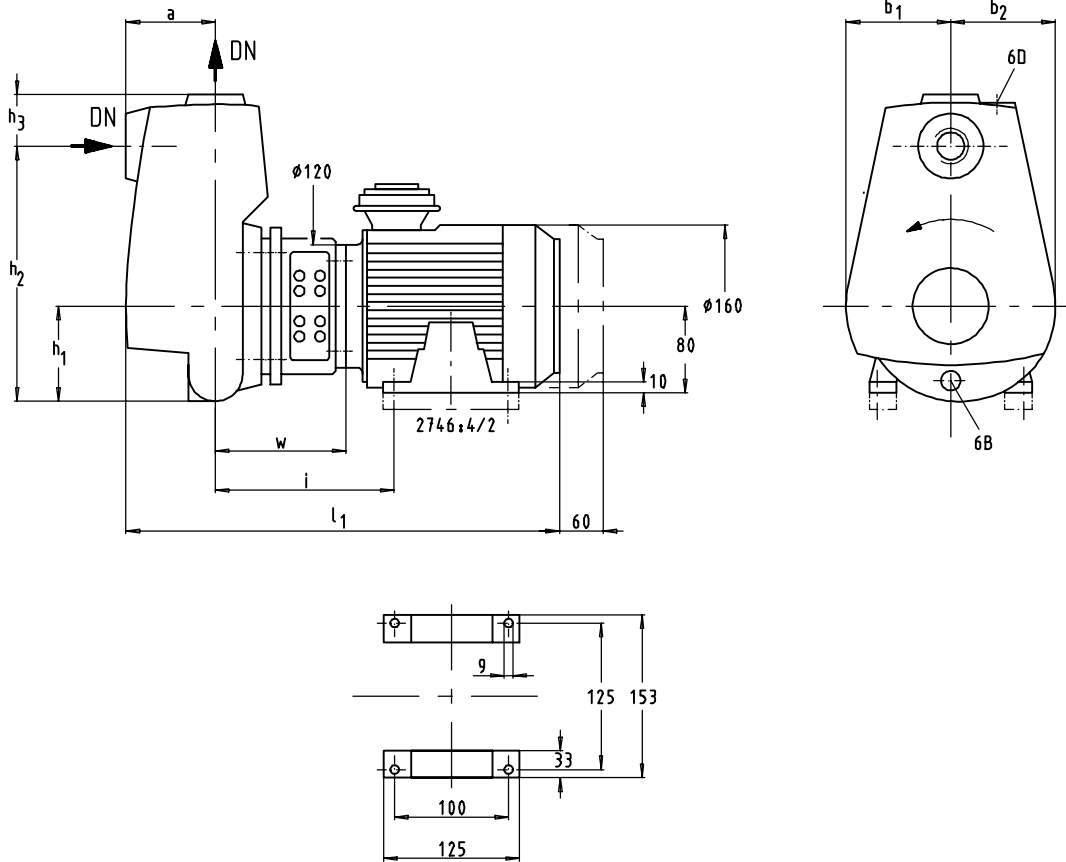
**Etaprime BN**

Etaprime BN	6 B <sup>1)</sup>	6 D <sup>1)</sup>
25-100/...	R <sub>c</sub> 1/8	R <sub>c</sub> 3/4
32-120/...	R <sub>c</sub> 1/8	R <sub>c</sub> 3/4
40-110/...	R <sub>c</sub> 1/8	R <sub>c</sub> 3/4

6 B	Förderflüssigkeit-Entleerung / Casing drain / Vidange du liquide véhiculé / Scarico del liquido convogliato / Vaciado del líquido de impulsión / aftap. pomphuis
6 D	Förderflüssigkeit-Auffüllen und Entlüften / Fluid handled-priming and venting / Remplissage et dégazage de liquide véhiculé / Riempimento e scarico del liquido convogliato / Llenado y desaireación del líquido de impulsión / vul en ontluchting

1) R<sub>c</sub> = ISO 7/1

Tolerances of connecting dimensions as per EN 735

mm

Etaprime BN <sup>4)</sup>	Connection				a	b <sub>1</sub>	b <sub>2</sub>	h <sub>1</sub>	h <sub>2</sub>	h <sub>3</sub>	i	l <sub>1</sub> ca.	w
	Standard DN <sup>2)</sup>	Special DN <sup>3)</sup>	n = 1.450 1/min	n = 1.750 1/min									
25-100 / 054	X	X			70	104	95	87	227	38	152	399	102
/ 112		X	X		70	104	95	87	227	38	152	399	102
32-120 / 054	X	X			95	118	95	90	239	46	149	421	99
/ 112		X	X		95	118	95	90	239	46	149	421	99
40-110 / 054	X	X			105	118	110	101	256	55	154	436	104
/ 112		X	X		105	118	110	101	256	55	154	436	104

2) Standard connection to ISO 7/1

3) Special connection to ASME B1.20.1

4) For these motor sizes, 30 mm thick shims etc. must be placed under the motor feet.

**Etaprime BN**

with motor foot from motor size 132 = 5.5 kW

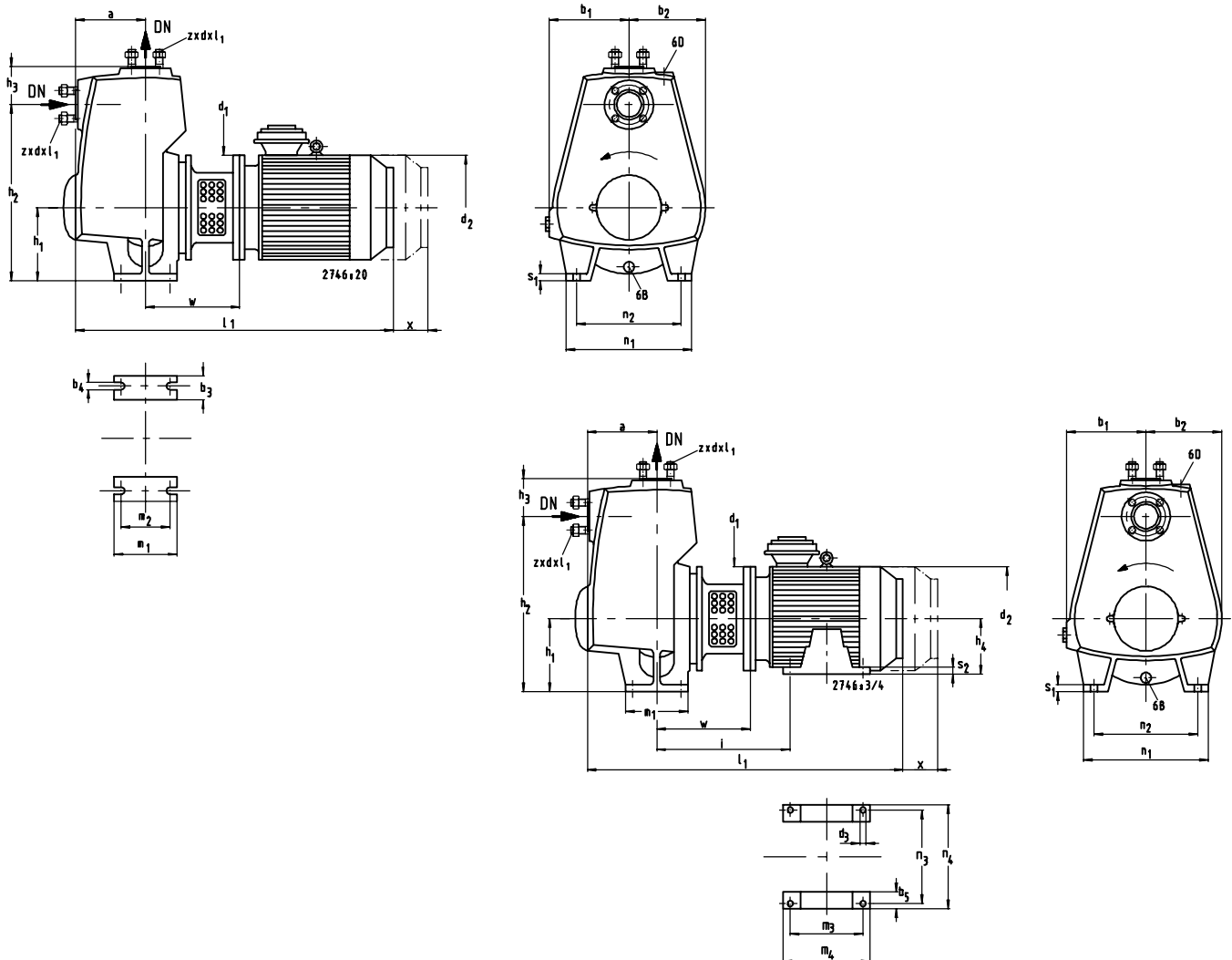

6 B	Förderflüssigkeit-Entleerung / Casing drain / Vidange du liquide véhiculé / Scarico del liquido convogliato / Vaciado del liquido de impulsión / aftap. pomphuis
6 D	Förderflüssigkeit-Auffüllen und Entlüften / Fluid handled-priming and venting / Remplissage et dégazage de liquide véhiculé / Riempimento e scarico del liquido convogliato / Llenado y desaireación del líquido de impulsión / vul en ontluchting

Etaprime BN	6 B <sup>1)</sup>	6 D <sup>1)</sup>
40-140/...	Rc 3/8	Rc 3/4
50-130/...	Rc 1/2	Rc 3/4
50-160/...	Rc 1/2	Rc 3/4
65-150/...	Rc 1/2	Rc 3/4
65-180/...	Rc 1/2	Rc 3/4
80-170/...	Rc 3/4	Rc 3/4
80-190/...	Rc 3/8	Rc 3/4
80-200/...	Rc 1/2	Rc 3/4
100-240.1/...	Rc 3/4	Rc 3/4

1) Rc = ISO 7/1

Flange dimensions					mm
Flange connection	DN	Dia. of bolt circle	z	d	l <sub>1</sub>
Standard EN 1092-1 EN 1092-2	40	110	4	M 16	40
	50	125			
	65	145	8		45
	80	160			
100	180				
Special ASME BE 16.1 Class 125 (ZN 2606)	40	98.6	4	UNC 1/2-13	40
	50	120.7			
	65	139.7			
	80	152.4			
	100	190.5			
		8	UNC 5/8-11	45	

## Tolerances of connecting dimensions as per EN 735

mm

Etaprime BN	n				DN	a	b <sub>1</sub>	b <sub>2</sub>	b <sub>3</sub>	b <sub>4</sub>	b <sub>5</sub>	d <sub>1</sub>	d <sub>2</sub>	d <sub>3</sub>	h <sub>1</sub>	h <sub>2</sub>	h <sub>3</sub>	h <sub>4</sub>	i	l <sub>1ca</sub>	m <sub>1</sub>	m <sub>2</sub>	m <sub>3</sub>	m <sub>4</sub>	n <sub>1</sub>	n <sub>2</sub>	n <sub>3</sub>	n <sub>4</sub>	s <sub>1</sub>	s <sub>2</sub>	w	x	
	1.450 1/min	1.750 1/min	2.900 1/min	3.500 1/min																													
40-140 / 054 / 154 / 222 / 302 / 402 / 552 2)	X				40	115	128	115	57	16	-	200	170	-	112	284	73	-	-	510	100	70	-	-	220	160	-	-	16	-	123	100	
		X			40	115	128	115	57	16	-	200	190	-	112	284	73	-	-	570	100	70	-	-	220	160	-	-	16	-	166	100	
			X		40	115	128	115	57	16	-	200	190	-	112	284	73	-	-	570	100	70	-	-	220	160	-	-	16	-	166	100	
				X	40	115	128	115	57	16	-	250	213	-	112	284	73	-	-	608	100	70	-	-	220	160	-	-	16	-	180	100	
					X	40	115	128	115	57	16	-	250	234	-	112	284	73	-	-	629	100	70	-	-	220	160	-	-	16	-	180	100
				X	40	115	128	115	57	16	43	300	266	12	112	284	73	132	292	717	100	70	140	220	220	160	216	270	16	15	203	100	
50-130 / 054 / 154 / 222 / 302 / 402	X				50	130	138	128	55	16	-	200	170	-	132	317	78	-	-	510	100	70	-	-	250	190	-	-	20	-	123	100	
		X			50	130	138	128	55	16	-	200	190	-	132	317	78	-	-	570	100	70	-	-	250	190	-	-	20	-	166	100	
			X		50	130	138	128	55	16	-	200	190	-	132	317	78	-	-	585	100	70	-	-	250	190	-	-	20	-	166	100	
				X	50	130	138	128	55	16	-	250	213	-	132	317	78	-	-	623	100	70	-	-	250	190	-	-	20	-	180	100	
					X	50	130	138	128	55	16	-	250	234	-	132	317	78	-	-	644	100	70	-	-	250	190	-	-	20	-	180	100
				X	50	130	145	126	55	16	43	300	266	12	132	327	75	132	292	732	100	70	140	220	250	190	216	270	20	15	203	100	
50-160 / 054 / 154 / 402 / 552 1) / 752 1)	X				50	130	145	126	55	16	-	200	170	-	132	327	75	-	-	510	100	70	-	-	250	190	-	-	20	-	123	100	
		X			50	130	145	126	55	16	-	200	190	-	132	327	75	-	-	570	100	70	-	-	250	190	-	-	20	-	166	100	
			X		50	130	145	126	55	16	-	250	234	-	132	327	75	-	-	644	100	70	-	-	250	190	-	-	20	-	180	100	
				X	50	130	145	126	55	16	43	300	266	12	132	327	75	132	292	732	100	70	140	220	250	190	216	270	20	15	203	100	
					X	50	130	145	126	55	16	43	300	266	12	132	327	75	132	292	732	100	70	140	220	250	190	216	270	20	15	203	100
				X	50	130	145	126	55	16	43	300	266	12	132	327	75	132	292	732	100	70	140	220	250	190	216	270	20	15	203	100	
65-150 / 054 / 154 / 402 / 552 1)2) / 752 1)2)	X				65	140	155	149	55	16	-	200	170	-	160	370	85	-	-	510	125	95	-	-	270	212	-	-	23	-	123	100	
		X			65	140	155	149	55	16	-	200	190	-	160	370	85	-	-	570	125	95	-	-	270	212	-	-	23	-	166	100	
			X		65	140	155	149	55	16	-	250	234	-	160	370	85	-	-	644	125	95	-	-	270	212	-	-	23	-	180	100	
				X	65	140	155	149	55	16	43	300	266	12	160	370	85	132	292	732	125	95	140	220	270	212	216	270	23	15	203	100	
					X	65	140	155	149	55	16	43	300	266	12	160	370	85	132	292	732	125	95	140	220	270	212	216	270	23	15	203	100
				X	65	140	155	149	55	16	43	300	266	12	160	370	85	132	292	732	125	95	140	220	270	212	216	270	23	15	203	100	
65-180 / 224 / 552 1)2) / 752 1)2) / 1102 1)	X	X			65	140	158	138	55	16	-	250	213	-	160	376	89	-	-	650	125	95	-	-	270	212	-	-	23	-	180	140	
			X		65	140	158	138	55	16	43	300	266	12	160	376	89	132	322	772	125	95	140	220	270	212	216	270	23	15	233	140	
				X	65	140	158	138	55	16	43	300	266	12	160	376	89	132	322	772	125	95	140	220	270	212	216	270	23	15	233	140	
					X	65	140	158	138	55	16	70	350	325	14	160	376	89	160	374	952	125	95	210	300	270	212	254	320	23	21	266	140
					X	80	156	173	168	65	18	-	250	213	-	160	380	104	-	-	650	140	106	-	-	310	240	-	-	21	-	180	140
					X	80	156	173	168	65	18	43	300	266	12	160	380	104	132	322	788	140	106	140	220	310	240	216	270	21	15	233	140
80-170 / 224 / 752 1)2) / 1102 1) / 1502 1)	X	X			80	156	173	168	65	18	43	300	266	12	160	380	104	132	322	788	140	106	140	220	310	240	216	270	21	15	233	140	
			X		80	156	173	168	65	18	70	350	325	14	160	380	104	160	374	968	140	106	210	300	310	240	254	320	21	21	266	140	
				X	80	156	173	168	65	18	70	350	325	14	160	380	104	160	374	968	140	106	210	300	310	240	254	320	21	21	266	140	
					X	80	156	173	168	65	18	70	350	325	14	160	380	104	160	374	968	140	106	210	300	310	240	254	320	21	21	266	140
					X	80	156	173	168	65	18	70	350	325	14	160	380	104	160	374	968	140	106	210	300	310	240	254	320	21	21	266	140
					X	80	156	173	168	65	18	70	350	325	14	160	380	104	160	374	968	140	106	210	300	310	240	254	320	21	21	266	140
80-190 / 224 / 1102 1)2) / 1502 1)2) / 1852 1)2)	X	X			80	170	188	181	65	20	-	250	213	-	180	420	107	-	-	650	160	120	-	-	345	280	-	-	25	-	180	140	
			X		80	170	188	181	65	20	70	350	325	14	180	420	107	160	374	982	160	120	210	300	345	280	254	320	25	21	266	140	
				X	80	170	188	181	65	20	70	350	325	14	180	420	107	160	374	982	160	120	210	300	345	280	254	320	25	21	266	140	
					X	80	170	188	181	65	20	70	350	325	14	180	420	107	160	374	982	160	120	254	314	345	280	254	320	25	21	266	140
					X	80	170	188	181	65	20	70	350	325	14	180	420	107	160	374	982	160	120	254	314	345	280	254	320	25	21	266	140
					X	80	170	188	181	65	20	70	350	325	14	180	420	107	160	374	982	160	120	254	314	345	280	254	320	25	21	266	140
80-200 / 224 / 1102 1) / 1502 1) / 1852 1)	X	X			80	154	172	152	65	20	-	250	213	-	160	378	107	-	-	650	140	100	-	-	285								

## Interchangeability of Etaprime B/BN and Etaprime L Components and Interchangeability of Component Parts

Etaprime B/BN	Shaft unit	Description					
		Volute casing	Casing cover	Shaft 1)	Impeller	Mechanical seal	Shaft sleeve
		Part No. 102	161	210	230	433.01	523
25-100	17	O	X	1	O	1	X
32-120		O	X	1	O	1	X
40-110		O	X	1	O	1	X
40-140	25	O	O	2	O	2	1
50-130		O	O	2	O	2	1
50-160		O	O	2	O	2	1
65-150		O	O	2	O	2	1
65-180	35	O	O	3	O	3	2
80-170		O	O	3	O	3	2
80-190		O	O	3	O	3	2
80-200		O	O	3	O	3	2
100-240.1		O	O	3	O	3	2

1) only for Etaprime GBN, CBN

1	Same number means same component
1	
O	Components differ
X	Component not fitted
	Component interchangeable with Etaprime L

## Recommended Spare Parts Stock for 2 Years' Continuous Operation to DIN 24 296

Part No.	Description	Number of Pumps (incl. stand-by pumps)						
		2	3	4	5	6 and 7	8 and 9	10 and more
		Quantity of spare parts						
210	Shaft 1)	1	1	1	2	2	2	20 %
230	Impeller	1	1	1	2	2	2	20 %
400.03	Gasket 2)	1	1	2	2	2	3	25 %
412.35/.65 1)	O-ring (set)	4	6	8	8	9	10	100 %
433.01	Mechanical seal	1	1	2	2	2	3	25 %
523	Shaft sleeve 2)	2	2	2	3	3	4	50 %

1) only for Etaprime GBN, CBN

2) not fitted on shaft unit 17

Applicable shaft unit/pump size combinations see above.

