

Axially Split Volute Casing Pump

RDLO / RDLO V

Type Series Booklet



Legal information/Copyright

Type Series Booklet RDLO / RDLO V

All rights reserved. The contents provided herein must neither be distributed, copied, reproduced, edited or processed for any other purpose, nor otherwise transmitted, published or made available to a third party without the manufacturer's express written consent.

Subject to technical modification without prior notice.

© KSB Aktiengesellschaft, Frankenthal 18.11.2013

Contents

Water Supply 4

 Axially Split Volute Casing Pump 4

 RDLO / RDLO V 4

 Main applications 4

 Fluids handled 4

 Operating data 4

 Designation 4

 Design details 4

 Materials 6

 Coating and preservation 7

 Product benefits 8

 Acceptance tests 8

 Selection information 9

 Solids content 9

 Directions of rotation and flow 9

 Overview of product features 10

 Specifications required for enquiries/orders 12

 Selection charts 13

 RDLO / RDLO V, n = 1480 rpm 13

 RDLO / RDLO V, n = 985 rpm 13

 RDLO / RDLO V, n = 740 rpm 14

 RDLO / RDLO V, n = 1780 rpm 14

 RDLO / RDLO V, n = 1180 rpm 15

 RDLO / RDLO V, n = 890 rpm 15

 RDLO / RDLO V, n = 715 rpm 16

 Installation types 17

 Fig.0 17

 2E 17

 3E 17

 4E 17

 DJ 18

 DP 18

 Scope of supply 19

 General assembly drawings with list of components 20

 Horizontal installation (example) 20

 Vertical installation (example) 22

Water Supply

Axially Split Volute Casing Pump

RDLO / RDLO V



Main applications

- Water supply systems
- Desalination plants
- Pressure boosting
- Water transport
- Service and cooling water for power stations and industry
- Irrigation and drainage pumping stations
- Fire-fighting systems
- Shipbuilding
- District heating and cooling systems

Fluids handled

RDLO / RDLO V pumps are designed for pumping water and other fluids with a low solids content. The pumps are very versatile and can be used for the following fluids, for example:

- Brackish water
- River, lake and groundwater
- Stormwater
- Service water
- Fire-fighting water
- Cooling water
- Condensate
- Heating water

- Drinking water

Operating data

Operating properties

Characteristic	Value	
Sizes	DN	350-700 mm [14-28 inch]
Flow rate ¹⁾	Q	Up to 10,000 m ³ /h [44,030 US.gpm]
Head ¹⁾²⁾	H	Up to 240 m [787 ft]
Operating pressure ²⁾	p	Up to 25 bar [363 psi]
Fluid temperature ³⁾	t	Up to + 80 °C [176 °F]

Designation

Example: RDLO V 350-690 A GB P M

Key to the designation

Code	Description	
RDLO	Type series	
V	Design	
	4)	Horizontal installation
	V	Vertical installation
350	Nominal discharge nozzle diameter [mm]	
700	Nominal impeller diameter [mm]	
A	Impeller type	
	A, B	
GB	Material variant (⇒ Page 6)	
	GB	Grey cast iron / bronze
	GC	Grey cast iron / chrome steel
	SB	Nodular cast iron / bronze
	SC	Nodular cast iron / chrome steel
	DD ₃₅	Duplex stainless steel / duplex stainless steel
P	Shaft seal	
	P	Gland packing
	G	Mechanical seal
M	Bearing lubrication	
	F	Grease
	M	Product-lubricated
	O	Oil lubrication

Design details

Design

- Volute casing pump
- Horizontal/vertical installation
- Single-stage
- Nominal diameter of the discharge nozzles: 350 mm to 700 mm

Pump casing

- Axially split volute casing
- Volute casing with integrally cast pump feet
- Replaceable casing wear rings

1) Higher flow rates or heads on request.

2) Depending on the material and size

3) Fluid temperatures of up to 140 °C [284 °F] on request.

4) Blank

- Mating dimensions to EN or ASME

Impeller type

- Double-entry radial impeller (optionally with impeller wear rings)

Pump shaft

- Completely dry shaft for design with rolling element bearings
- Shaft protecting sleeves in the seal area

Shaft seal

- Gland packing

- Balanced mechanical seal

Bearings

For horizontal installation:

- Grease-packed rolling element bearings
- Oil-lubricated rolling element bearings

For vertical installation:

- Grease-packed rolling element bearings
- Bottom: product-lubricated rubber plain bearing / Top: grease-packed rolling element bearing

Materials

Overview of material variants

Part No.	Description	Material variant				
		GB	GC	SB	SC	DD ₃₅ ⁵⁾
All pump sets						
102	Volute casing	Grey cast iron	Grey cast iron	Nodular cast iron	Nodular cast iron	Duplex stainless steel
211	Pump shaft	Stainless steel	Stainless steel	Stainless steel	Stainless steel	Duplex stainless steel
234	Impeller	Bronze	Stainless steel	Bronze	Stainless steel	Duplex stainless steel
350.01	Bearing housing	Grey cast iron	Grey cast iron	Grey cast iron	Grey cast iron	Grey cast iron
360.01	Bearing cover	Steel	Steel	Steel	Steel	Steel
441	Shaft seal housing	Grey cast iron	Grey cast iron	Grey cast iron	Grey cast iron	Duplex stainless steel
502	Casing wear ring	Bronze	Stainless steel	Bronze	Stainless steel	Duplex stainless steel
503	Impeller wear ring (optional)	Bronze	Stainless steel	Bronze	Stainless steel	Duplex stainless steel
525.01	Spacer sleeve	Bronze	Bronze	Bronze	Bronze	Duplex stainless steel
For pump sets with ball bearings on both sides only						
350.02	Bearing housing	Grey cast iron	Grey cast iron	Grey cast iron	Grey cast iron	Grey cast iron
360.02	Bearing cover	Unalloyed steel ⁶⁾	Unalloyed steel ⁶⁾	Unalloyed steel ⁶⁾	Unalloyed steel ⁶⁾	Unalloyed steel ⁶⁾
525.03	Spacer sleeve	Bronze	Bronze	Bronze	Bronze	Duplex stainless steel
For pump sets with product-lubricated plain bearing only						
524.03	Shaft protecting sleeve	Stainless steel	Stainless steel	Stainless steel	Stainless steel	-
525.02	Spacer sleeve	Bronze	Bronze	Bronze	Bronze	-
525.04	Spacer sleeve	Bronze	Bronze	Bronze	Bronze	-
545	Bearing bush	Bronze/rubber	Bronze/rubber	Bronze/rubber	Bronze/rubber	-
550.03	Disc	Stainless steel	Stainless steel	Stainless steel	Stainless steel	-
For pump sets with gland packing only						
452	Gland follower	Nodular cast iron	Nodular cast iron	Nodular cast iron	Nodular cast iron	-
457.01	Neck ring (p < 7bar)	Bronze	Bronze	Bronze	Bronze	-
457.03	Neck ring (p >7 bar)	Bronze	Bronze	Bronze	Bronze	-
458	Lantern ring	Bronze	Bronze	Bronze	Bronze	-
461	Packing ring	Ramie fibre PTFE-impregnated	Ramie fibre PTFE-impregnated	Ramie fibre PTFE-impregnated	Ramie fibre PTFE-impregnated	-
524.01	Shaft protecting sleeve	Stainless steel	Stainless steel	Stainless steel	Stainless steel	-
For pump sets with mechanical seal only						
433	Balanced mechanical seal	Carbon/silicon carbide	Carbon/silicon carbide	Carbon/silicon carbide	Carbon/silicon carbide	Carbon/silicon carbide
457.02	Neck ring	Bronze	Bronze	Bronze	Bronze	Duplex stainless steel
471	Seal cover	Stainless steel	Stainless steel	Stainless steel	Stainless steel	Duplex stainless steel
524.02	Shaft protecting sleeve	Bronze	Bronze	Bronze	Bronze	Duplex stainless steel

⁵⁾ PREN ≤ 35 only applies to the main cast components (volute casing, impeller, shaft seal housing). Duplex stainless steels with special PREN values available on request.

⁶⁾ For RDLO V only

Coating and preservation

Coating for indoor installation

Coating type	Material variant					Casing			Base frame
	GB	GC	SB	SC	DD ₃₅	Exterior	Interior	Bearing housing	
A1	X	X	X	X	–	Epoxy resin base paint, colour RAL 5002 (ultramarine blue) ⁷⁾	Epoxy resin base primer, colour at our discretion	Epoxy resin base paint, colour RAL 5002 (ultramarine blue) ⁷⁾	Epoxy resin base paint, colour RAL 5002 (ultramarine blue) ⁷⁾
A1-E ⁸⁾	X	X	X	X	–	Epoxy resin base paint, colour RAL 5002 (ultramarine blue) ⁷⁾	Epoxy resin base paint, colour RAL 5015 (sky blue) ⁹⁾	Epoxy resin base paint, colour RAL 5002 (ultramarine blue) ⁷⁾	Epoxy resin base paint, colour RAL 5002 (ultramarine blue) ⁷⁾
B1-E	–	–	–	–	X	Epoxy resin base paint, colour RAL 5002 (ultramarine blue) ⁷⁾	None; sand-blasted SA 2 ½	Epoxy resin base paint, colour RAL 5002 (ultramarine blue) ⁷⁾	Epoxy resin base paint, colour RAL 5002 (ultramarine blue) ⁷⁾

Coating for outdoor installation

Coating type	Material variant					Casing			Base frame
	GB	GC	SB	SC	DD ₃₅	Exterior	Interior	Bearing housing	
A2	X	X	X	X	–	Polyurethane base paint, colour RAL 5002 (ultramarine blue) ¹⁰⁾	Epoxy resin base primer, colour at our discretion	Polyurethane base paint, colour RAL 5002 (ultramarine blue) ¹⁰⁾	Polyurethane base paint, colour RAL 5002 (ultramarine blue) ¹⁰⁾
A2-E ⁸⁾	X	X	X	X	–	Polyurethane base paint, colour RAL 5002 (ultramarine blue) ¹⁰⁾	Epoxy resin base primer, colour RAL 5015 (sky blue) ⁹⁾	Polyurethane base paint, colour RAL 5002 (ultramarine blue) ¹⁰⁾	Polyurethane base paint, colour RAL 5002 (ultramarine blue) ¹⁰⁾
B2-E	–	–	–	–	X	Polyurethane base paint, colour RAL 5002 (ultramarine blue) ¹⁰⁾	None; sand-blasted SA 2 ½	Polyurethane base paint, colour RAL 5002 (ultramarine blue) ¹⁰⁾	Polyurethane base paint, colour RAL 5002 (ultramarine blue) ¹⁰⁾

7) For indoor use in industry and in a marine atmosphere; other colours only in coating variants A2 or B2 and on request.

8) Surcharge

9) Approved for drinking water (KTW, DVGW, ACS). The impeller and rotor components are generally not coated. No other colours available. Max. permissible temperature for drinking water approved coating 60 °C [140 °F]. Only approved for drinking water up to 25 °C [77 °F] max.

10) For indoor and outdoor use in industry and in a marine atmosphere; other colours on request.

Product benefits

- Low maintenance costs:
 - Fast and easy to install thanks to self-centring components (upper casing part, rotor, casing cover)
 - Materials resistant to corrosion and abrasion
 - Smooth operation with low vibration levels
 - Replacement and spare parts fit several pump sizes
- Long service life:
 - Sealed and dry shaft
 - Short bearing distances and a short shaft
 - Protected rolling element bearings greased for life
 - Optional impeller wear rings
 - Replaceable shaft protecting sleeve
- High operating reliability:
 - Rigid shaft without threads between the bearings
 - Generously sized bearings ($L_{h_{10}} = 100,000$ hours)
 - Reliable sealing thanks to solid casing split flange
 - Double-entry impeller for axial thrust balancing
 - Double volute design
- High flexibility:
 - Drive can be positioned to the left or right of the pump

- Shaft sealed by gland packing or mechanical seals
- Various horizontal and vertical installation options
- Flanges to DIN or ASME
- Excellent efficiencies and NPSH values:
 - Computer-optimised impellers
 - Large impeller inlet diameters for optimum suction behaviour
 - Cost-effective replacing of casing and impeller wear rings
 - Vortex-free intake elbow with low energy losses
 - Impeller trimmed to match the specified duty point
 - Several hydraulic systems per pump size

Acceptance tests

- Functional and acceptance tests
 - For information on acceptance tests and inspections refer to the QCPs (see KSB Standard ZN56555-2A ZN56555-2B ZN56555-2C)
- Quality assurance system
 - DIN ISO 9001 / EN 29001

Selection information

Solids content

Solids content by shaft seal and material variant in [ppm] or [mg/l]

Shaft seal	Material variant					
	Max. permissible solids content for variants with barrier and flushing water line without cyclone separator			Max. permissible solids content for variants with barrier and flushing water line with cyclone separator ¹¹⁾		
	Grey cast iron (GB/GC)	Nodular cast iron (SB/SC)	Cast steel (DD ₃₅)	Grey cast iron (GB/GC)	Nodular cast iron (SB/SC)	Cast steel (DD ₃₅)
Gland packing	50	50	50	100	100	100
Balanced mechanical seal	50	50	50	100	100	100

Directions of rotation and flow

Directions of rotation and flow

RDLO: variant for horizontal installation		RDLO V: variant for vertical installation	
Direction of rotation when looking at the shaft stub			
"Right" = clockwise	"Left" = anti-clockwise	"Right" = clockwise	"Left" = anti-clockwise

¹¹⁾ Higher solids contents on request

Overview of product features

General overview

Features	RDLO				RDLO V	
	Fig.0	2E	3E	4E	DP	DJ
Acceptance tests¹²⁾						
Hydraulic acceptance test to KSB standard (DIN ISO 9906 - 2B)	●	●	●	●	●	●
Hydraulic acceptance test to DIN ISO 9906 - 1B	○	○	○	○	○	○
Hydraulic acceptance test to DIN ISO 9906 – 1U (Hydraulic Institute A)	○	○	○	○	○	○
NPSH test (to DIN ISO 9906 or Hydraulic Institute A)	□	□	□	□	□	□
Sound measurement	□	□	□	□	□	□
Vibration measurement	□	□	□	□	□	□
Bearing temperature measurement	□	□	□	□	□	□
Visual inspection after test run (strip test)	□	□	□	□	□	□
Hydrostatic test	□	□	□	□	□	□
Impeller balancing test	□	□	□	□	□	□
Coating						
Coating for indoor installation (KSB blue / RAL 5002)	●	●	●	●	●	●
Coating for outdoor installation (KSB blue / RAL 5002)	□	□	□	□	□	□
Coating approved for drinking water ¹³⁾	□	□	□	□	□	□
Coating for outdoor installation (special colour)	□	□	□	□	□	□
Special coating (customised coating system/composition)	14)	14)	14)	14)	14)	14)
Installation parts						
Without installation parts	●	-	-	-	-	-
Pump and motor (separate) on foundation rails (including foundation bolts)	-	□	-	-	-	-
Pump and motor on a common base frame (including foundation bolts)	-	-	□	-	-	-
Pump and motor on separate base frames (including foundation bolts)	-	-	-	□	-	-
Special base frame for pump and motor (including foundation bolts)	-	14)	14)	14)	-	-
Pump base frame (foot) including foundation bolts, and motor pedestal including foundation rails and foundation bolts	-	-	-	-	□	-
Pump base frame (foot) including foundation bolts	-	-	-	-	-	●
Pump base frame (foot) including foundation bolts, separate motor support frame for installation on a different floor, including foundation rails and foundation bolts	-	-	-	-	-	14)
Special base frame (foot) including foundation bolts, and motor pedestal including foundation rails and foundation bolts	-	-	-	-	14)	-
Direction of rotation						
"Right": clockwise	●	●	●	●	●	●
"Left": anti-clockwise	●	●	●	●	●	●
Flange						
DIN EN 1092 (all DN) – flat face (type A)	●	●	●	●	●	●
DIN EN 1092 (all DN) – raised face (type B)	□	□	□	□	□	□
ASME B16 (up to DN 600) – flat face (type FF)	●	●	●	●	●	●
ASME B16 (up to DN 600) – raised face (type RF)	□	□	□	□	□	□
Coupling						
Without coupling and coupling guard	●	●	●	●	●	●
Torsionally flexible 3-piece jaw coupling (coupling guard not tread-proof)	□	□	□	□	-	-
Torsionally flexible 3-piece jaw coupling (coupling guard tread-proof)	-	-	□	-	-	-
Torsion-resistant flexible disc coupling with spacer (coupling guard not tread-proof)	14)	□	□	□	□	14)
Torsion-resistant flexible disc coupling with spacer (coupling guard tread-proof)	-	-	□	-	-	-
Bearings						
Grease-lubricated rolling element bearing at the drive end	●	●	●	●	●	●
Grease-lubricated rolling element bearing at the non-drive end	●	●	●	●	-	-
Product-lubricated plain bearing at the non-drive end ¹³⁾¹⁵⁾	-	-	-	-	●	●
Oil-lubricated rolling element bearings at both ends	●	●	●	●	-	-
Motor						
Without motor	●	●	●	●	●	●
Low-voltage motor to IEC standard (make selected by KSB) ¹⁶⁾¹⁷⁾¹⁸⁾	□	□	●	●	●	●

¹²⁾ Scope and tests/inspections as per Standard QCP ZN56555 2A / ZN56555-2B / ZN565552C

¹³⁾ Only permissible up to and including fluid temperature 60 °C

¹⁴⁾ On request

¹⁵⁾ Not possible for material variant DD₃₅

¹⁶⁾ Cannot be supplied as an assembled pump set. To be assembled by the customer at the customer's site.

Features	RDLO				RDLO V	
	Fig.0	2E	3E	4E	DP	DJ
Low-voltage motor to IEC standard (make to KSB standard) ¹⁶⁾¹⁷⁾¹⁸⁾	□	□	□	□	□	□
Special motor to customer requirements (make not documented) ¹⁶⁾¹⁷⁾¹⁸⁾	14)	14)	14)	14)	14)	14)
Wear rings						
Casing with wear rings / impeller without wear rings	●	●	●	●	●	●
Casing with wear rings / impeller with wear rings	○	○	○	○	○	○
Piping						
Barrier fluid / flushing water line made of flexible PTFE (malleable cast iron)	●	●	●	●	●	●
Barrier fluid / flushing water line made of flexible PTFE (stainless steel) ¹⁵⁾	○	○	○	○	○	○
Barrier fluid / flushing water line made of flexible PTFE (duplex) ¹⁹⁾	○	○	○	○	○	○
Special piping (to customer requirements)	14)	14)	14)	14)	14)	14)
Shaft seal						
Gland packing ¹⁵⁾	●	●	●	●	●	●
Single mechanical seal (balanced)	○	○	○	○	○	○
Special shaft seal (make/design different to KSB specifications)	14)	14)	14)	14)	14)	14)
Accessories						
Cyclone separator ¹⁵⁾	○	○	○	○	○	○
Manually actuated vent valve (without additional piping) ²⁰⁾	○	○	○	○	○	○
Manually actuated drain valves (without additional piping) ²⁰⁾	○	○	○	○	○	○
PumpMeter	-	-	-	-	-	-
Temperature sensor for PT100 ²⁰⁾²¹⁾	○	○	○	○	○	○
Limit switch for PT100 ²⁰⁾²¹⁾	○	○	○	○	○	○
Transmitter for PT100 ²⁰⁾²¹⁾	○	○	○	○	○	○
Measuring nipple (SPM) for manual vibration measurement ²⁰⁾²¹⁾	○	○	○	○	○	○
Vibration sensor including vibration monitoring device ²⁰⁾²¹⁾	○	○	○	○	○	○
Pressure gauge nominal diameter 100 or 160, including valves (without attenuation) ¹⁵⁾²⁰⁾²¹⁾	○	○	○	○	○	○
Pressure gauge nominal diameter 100 or 160, including valves (with attenuation) ²⁰⁾²¹⁾	○	○	○	○	○	○

Key to the symbols

Symbol	Description
●	Standard design
○	Standard variant ²²⁾

Symbol	Description
□	Special design ²²⁾
-	Selection unavailable

- 17) The motor can be supplied by the customer and mounted at the site of installation.
 18) On request, customer-supplied motors can be mounted by KSB at the customer's site.
 19) Not available for material variants GB / GC / SB / SC
 20) If no valve or measuring equipment is selected as accessory the corresponding connection is closed with a plug.
 21) Measuring equipment is supplied with the pump but not fitted. It has to be connected at the time of commissioning of the pump. This connection is closed with a plug when the pump is supplied.
 22) A surcharge and longer delivery times apply to standard variants and special designs.

Specifications required for enquiries/orders

Pump:

- Designation of the pump
- Maximum and minimum inlet pressure
- Flow rate Q, head H_{total}
- Flange design
- Shaft seal
- Type and temperature of the fluid pumped
- Solids content
- Direction of rotation / motor position
- Accessories required
- Special inspections and acceptance tests

- Quantity and language of operating manuals

Drive (selected by KSB):

- Type of construction
- Enclosure
- Voltage, frequency, starting method
- Ambient temperature
- Thermal class
- Accessories required

Drive (selected by customer):

- Binding data sheet with motor dimensions and effective speed

Selection charts

RDLO / RDLO V, n = 1480 rpm

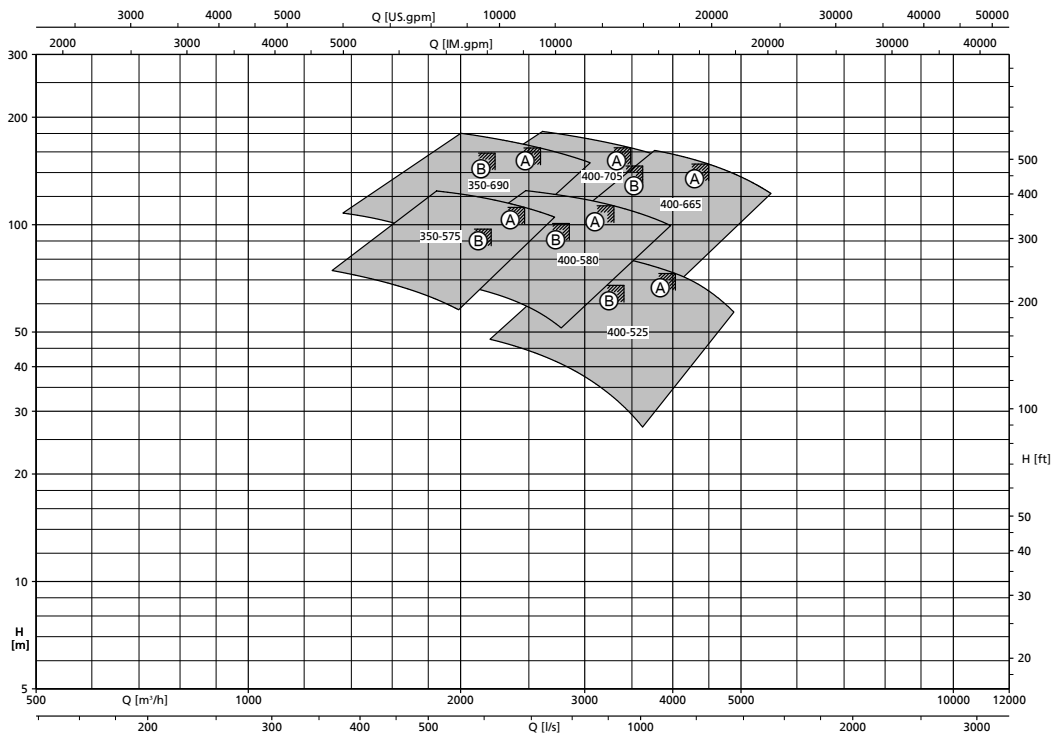

(A)	Impeller type A
(B)	Impeller type B

RDLO / RDLO V, n = 985 rpm

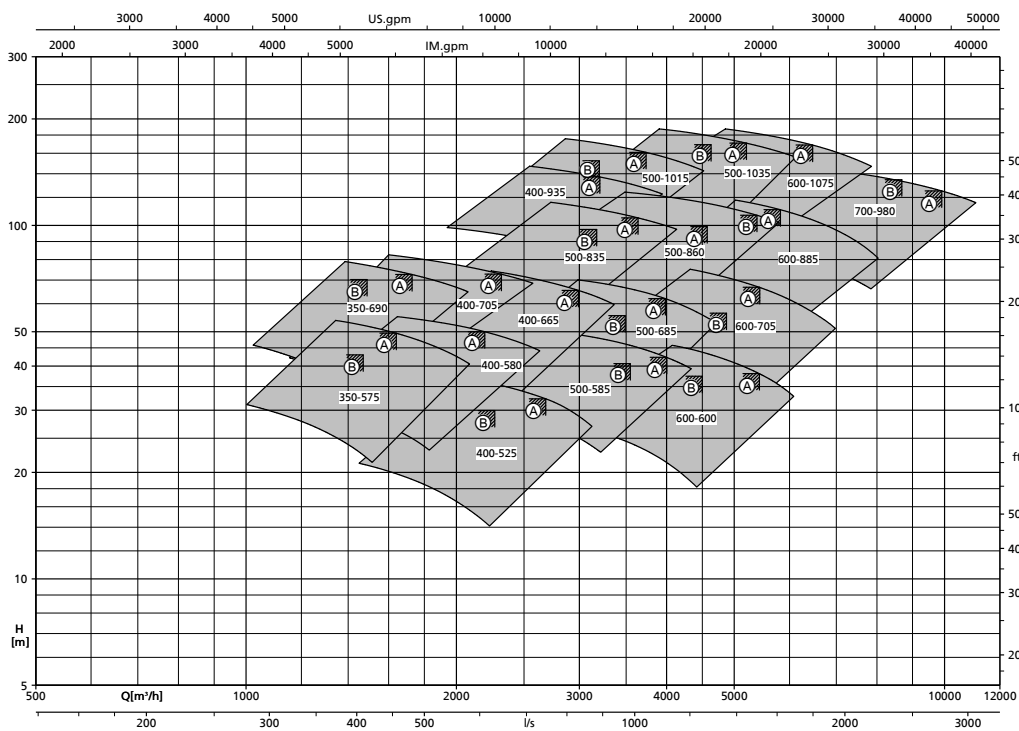

(A)	Impeller type A
(B)	Impeller type B

RDLO / RDLO V, n = 740 rpm

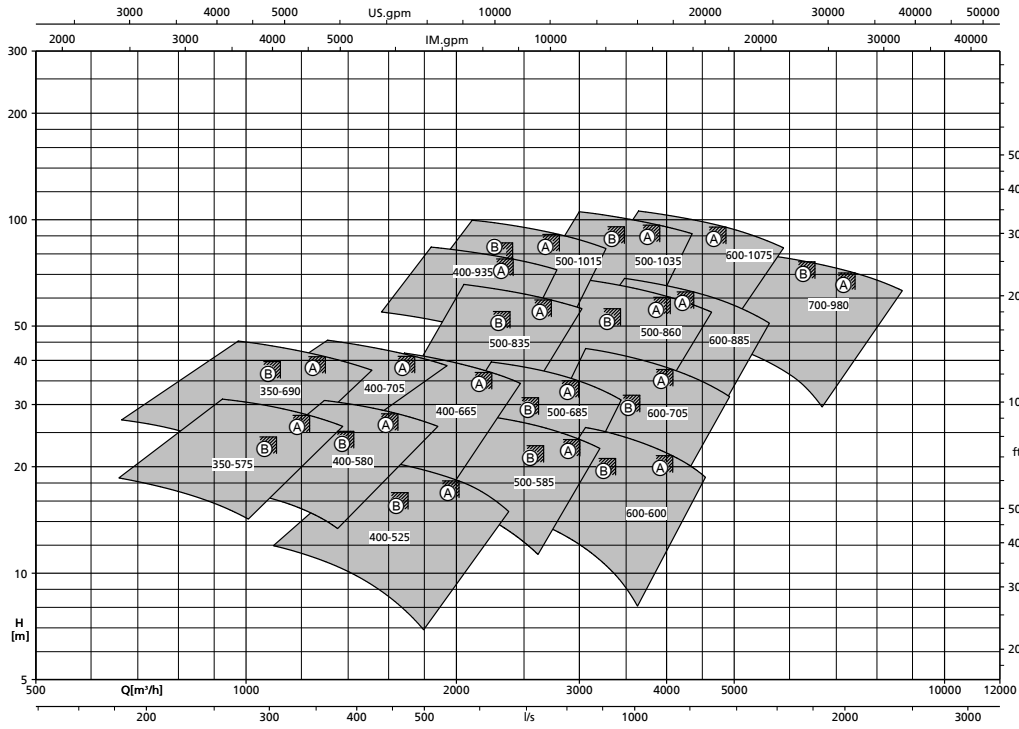

Ⓐ	Impeller type A
Ⓑ	Impeller type B

RDLO / RDLO V, n = 1780 rpm

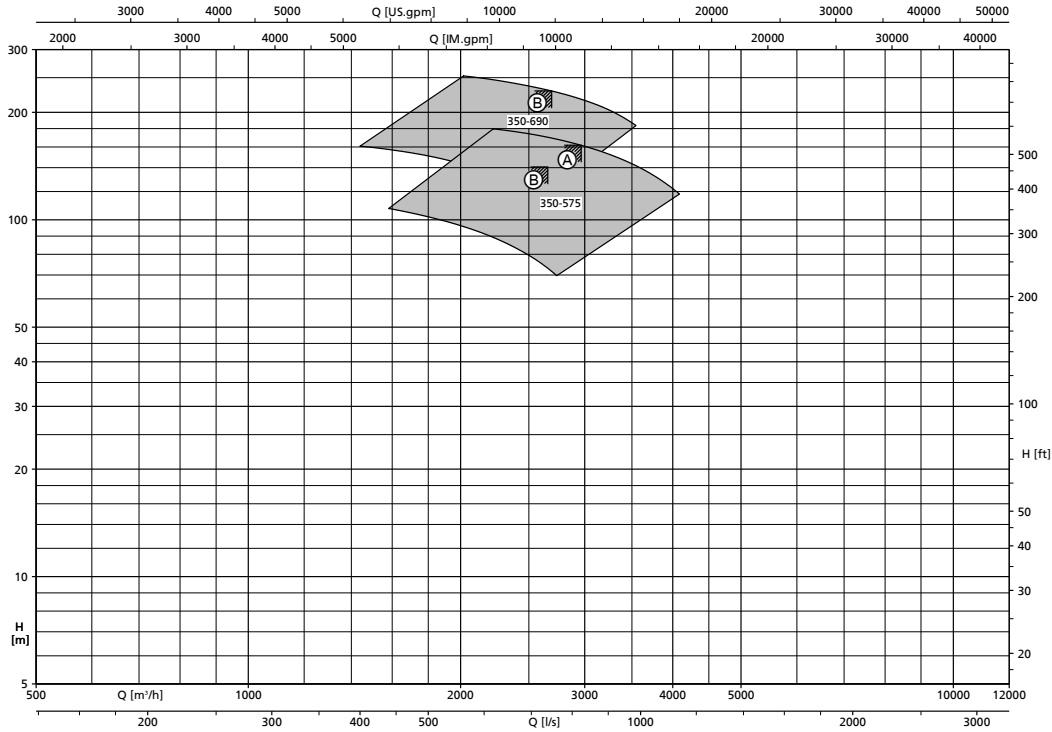

Ⓐ	Impeller type A
Ⓑ	Impeller type B

RDLO / RDLO V, n = 1180 rpm

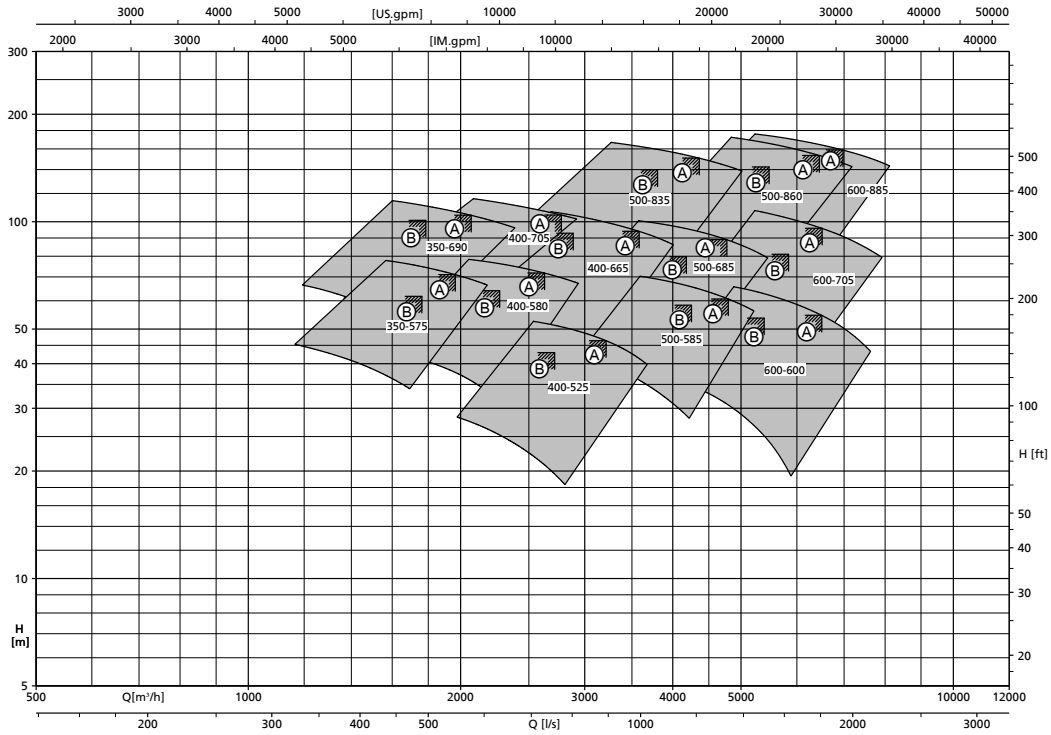

Ⓐ	Impeller type A
Ⓑ	Impeller type B

RDLO / RDLO V, n = 890 rpm

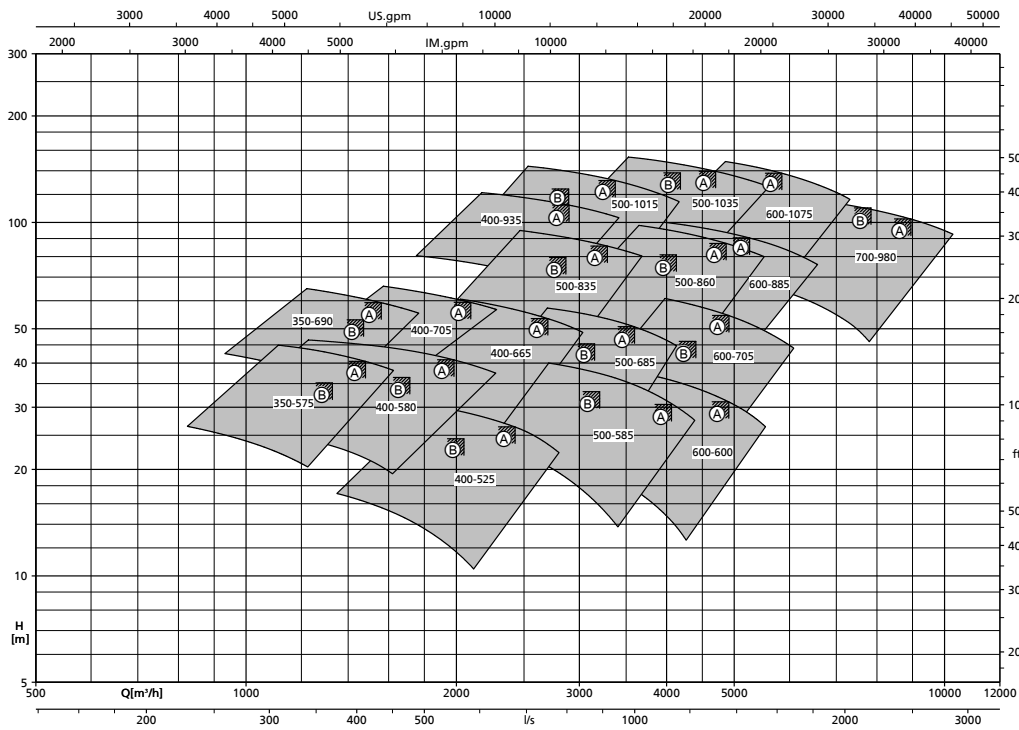

Ⓐ	Impeller type A
Ⓑ	Impeller type B

RDLO / RDLO V, n = 715 rpm

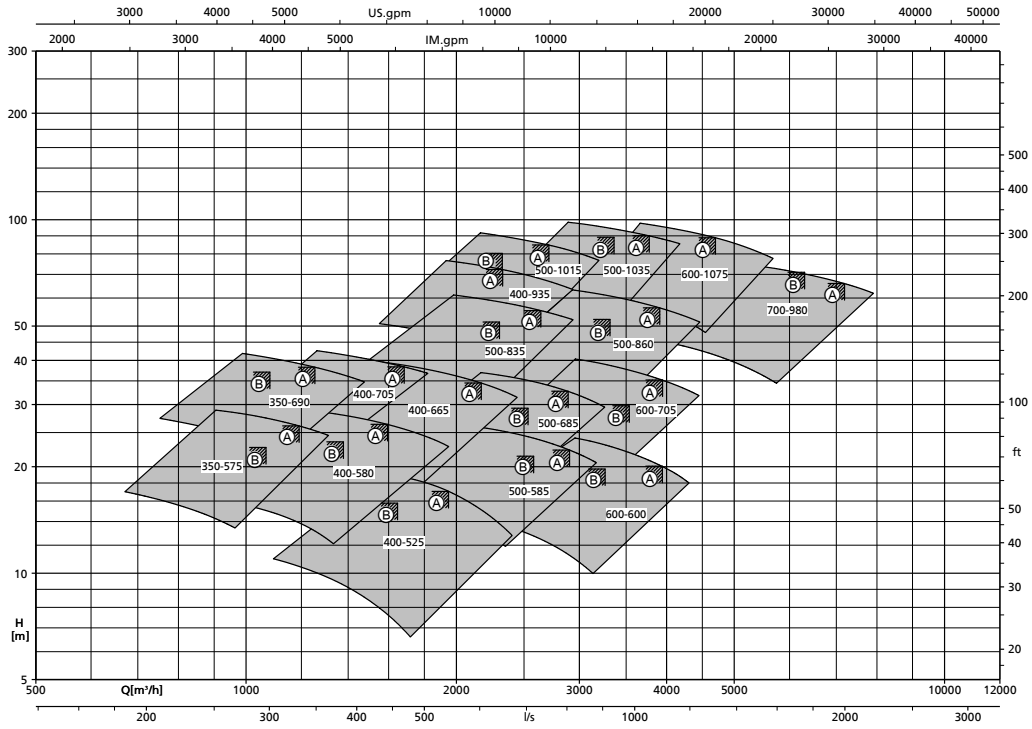

Ⓐ	Impeller type A
Ⓑ	Impeller type B

Installation types

Fig.0

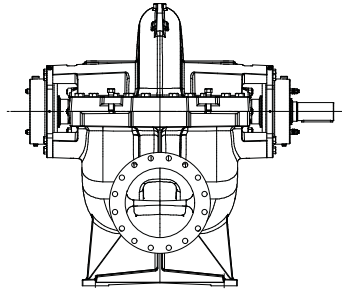

Fig.0: Bare shaft pump

Options of installation parts:

- No optional equipment

Coupling options:

- Torsionally flexible 3-piece jaw coupling
- Torsion-resistant flexible disc coupling

Coupling guard options:

- Light-duty design, not tread-proof

Delivery/transport:

- Pump

2E

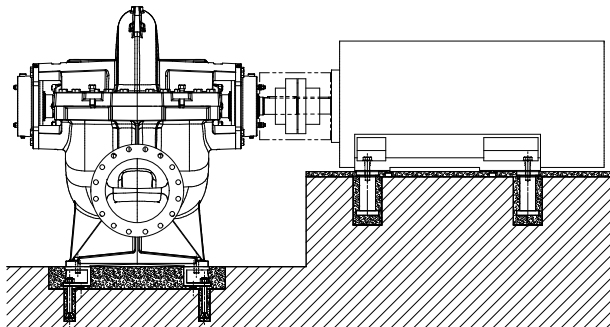

2E: pump and motor on foundation rails

Options of installation parts:

- Foundation rails for the pump, including foundation bolts, and foundation blocks for the motor
- Foundation rails for the pump, including foundation bolts

Coupling options:

- Torsionally flexible 3-piece jaw coupling
- Torsion-resistant flexible disc coupling with spacer

Coupling guard options:

- Light-duty design, not tread-proof

Delivery/transport:

- Pump and motor are supplied as separate units.

3E

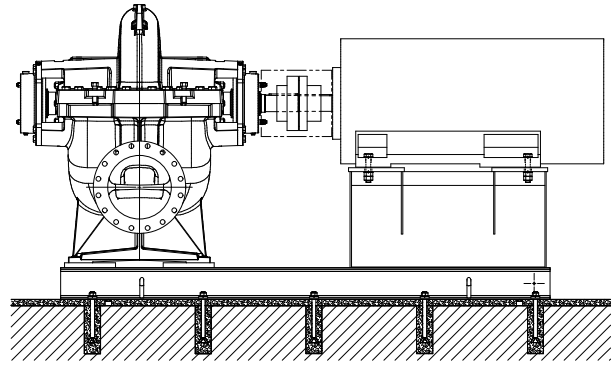

3E: Pump and motor on a common base frame

Options of installation parts:

- Base frame for pump and motor, including foundation bolts
- Special base frame for pump and motor, including foundation bolts

Coupling options:

- Torsionally flexible 3-piece jaw coupling
- Torsion-resistant flexible disc coupling with spacer²³⁾

Coupling guard options:

- Light-duty design, not tread-proof
- Heavy-duty design, tread-proof

Delivery/transport:

- Pump, motor and base frame are supplied as separate units.

4E

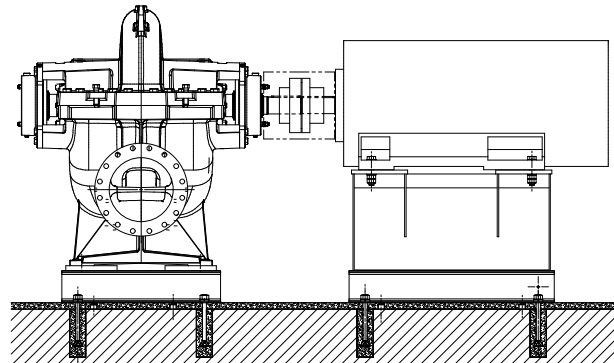

4E: Pump and motor on separate base frames

Options of installation parts:

- Base frame for the pump and base frame for the motor, including foundation bolts (without drip tray)
- Base frame for the pump, including foundation bolts (without drip tray)

Coupling options:

- Torsionally flexible 3-piece jaw coupling
- Torsion-resistant flexible disc coupling with spacer

Coupling guard options:

²³⁾ On request only

- Light-duty design, not tread-proof

Delivery/transport:

- Pump, motor and base frame are supplied as separate units.

DJ

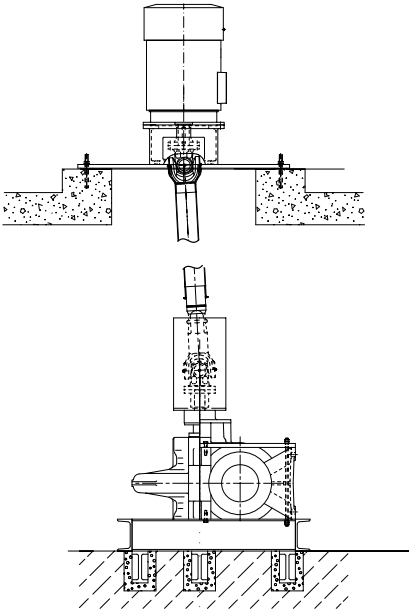

DJ: Pump and motor on separate levels

Options of installation parts:

- Pump base frame (foot) including foundation bolts
- Pump base frame (foot) including foundation bolts, motor support frame, foundation rails and foundation bolts²⁴⁾

Coupling options:

- Cardan shaft²⁴⁾
- Coupling with spacer²⁴⁾

Coupling guard options:

- Light-duty design, not tread-proof

Delivery / transport:

- Pump on corresponding pump base frame (foot), motor and motor support frame are supplied as separate units.

DP

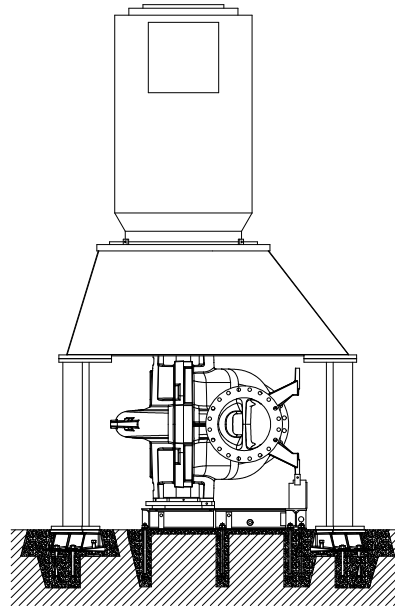

DP: motor mounted on separate drive lantern

Options of installation parts:

- Pump base frame (foot) including foundation bolts, and drive lantern (including foundation rails and foundation bolts)

Coupling options:

- Torsion-resistant flexible disc coupling with spacer

Coupling guard options:

- Light-duty design, not tread-proof

Delivery/transport:

- Pump with pump base frame (foot), motor and drive lantern supplied as individual units

²⁴⁾ On request only

Scope of supply

Depending on the model, the following items are included in the scope of supply:

- Pump
 - Drive
 - Baseplate
 - Coupling, coupling guard
 - Cardan shaft
 - Fasteners for pump and base frame
- Optional accessories:
 - Vibration monitoring
 - PT 100
 - Constant level oiler
 - Pressure gauge
 - Measuring nipple for shock pulse measurement
 - Cyclone

General assembly drawings with list of components

Horizontal installation (example)

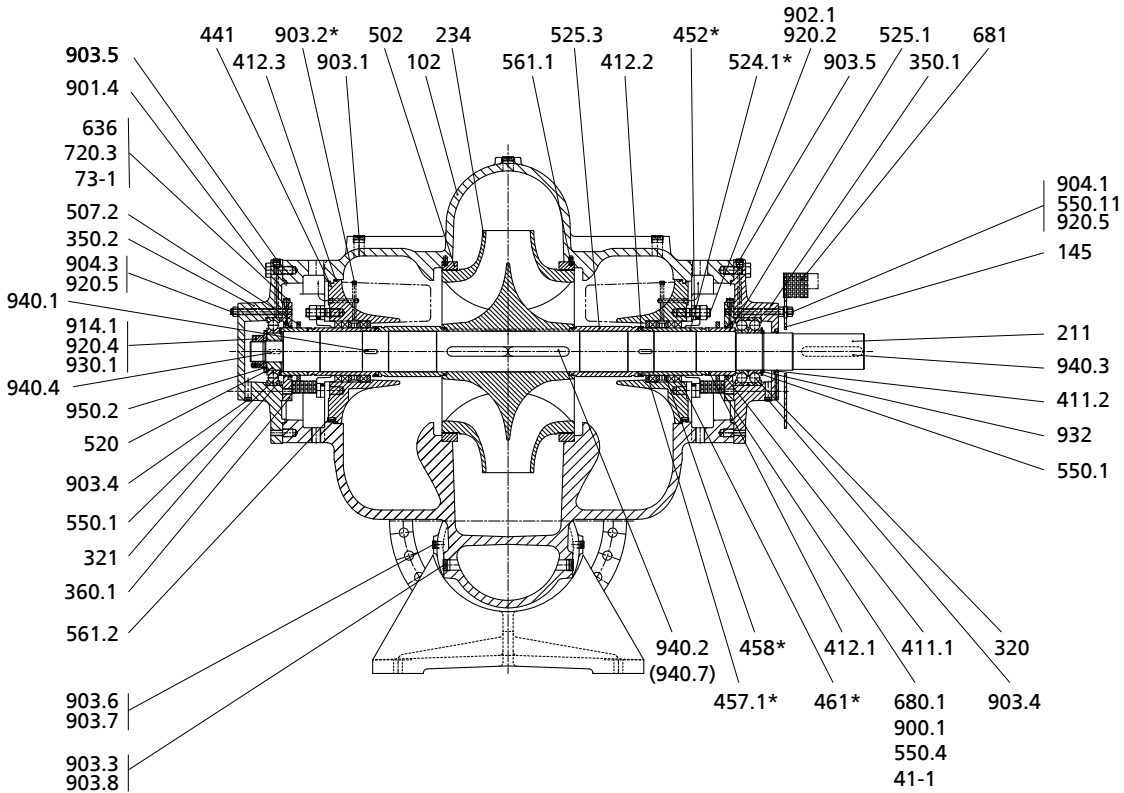

Horizontal installation: * = only for pump sets with gland packing for pump discharge pressure < 7 bar

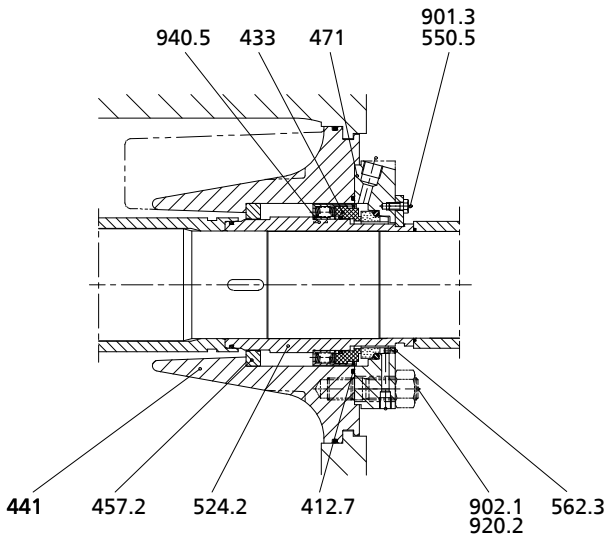

Detailed view: mechanical seal

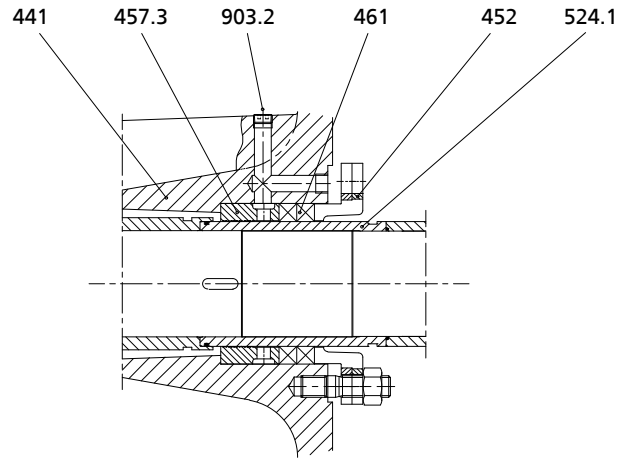

Detailed view: gland packing, pump discharge pressure ≥ 7 bar

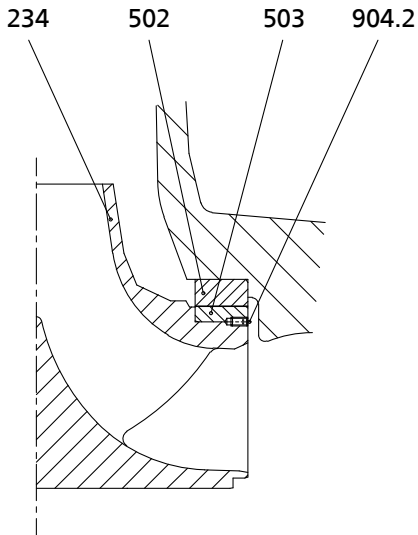

Detailed view: impeller with impeller wear ring

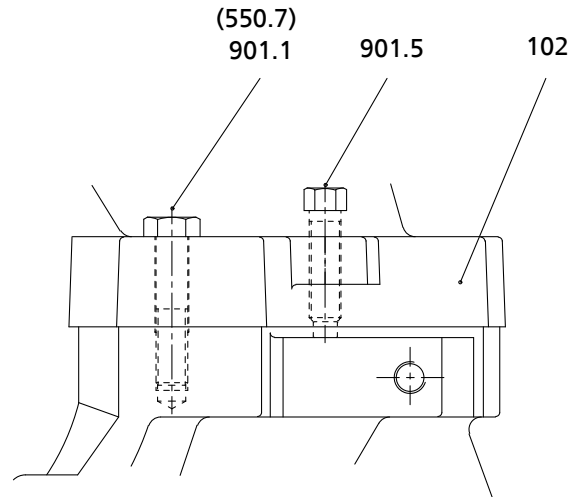

Detailed view: screwed connection of the casing split flange

List of components

Part No.	Designation	Part No.	Designation
102	Volute casing	524.1/2	Shaft protecting sleeve
145	Adapter	525.1/3	Spacer sleeve
211	Pump shaft	550.1/4/5/7/11	Disc
234	Impeller	561.1/2	Grooved pin
320	Rolling element bearing	562.3	Parallel pin
321	Radial ball bearing	636	Lubricating nipple
350.1/2	Bearing housing	680.1	Guard
360.1	Bearing cover	681	Coupling guard
41-1	Sealing washer	73-1	Socket
411.1/2	Joint ring	720.3	Spacer
412.1/2/3/7	O-ring	900.1	Screw
433	Mechanical seal	901.1/3/4/5	Hexagon head bolt
441	Shaft seal housing	902.1	Stud
452	Gland follower	903.1/2/3/4/5/6/7/8	Screw plug
457.1/2/3	Neck ring	904.1/2/3	Grub screw
458	Lantern ring	914.1	Hexagon socket head cap screw
461	Gland packing	920.2/4/5	Nut
471	Seal cover	930.1	Safety device
502	Casing wear ring	932	Circlip
503	Impeller wear ring	940.1/2/3/4/5/7	Key
507.2	Thrower	950.2	Spring
520	Sleeve		

Vertical installation (example)

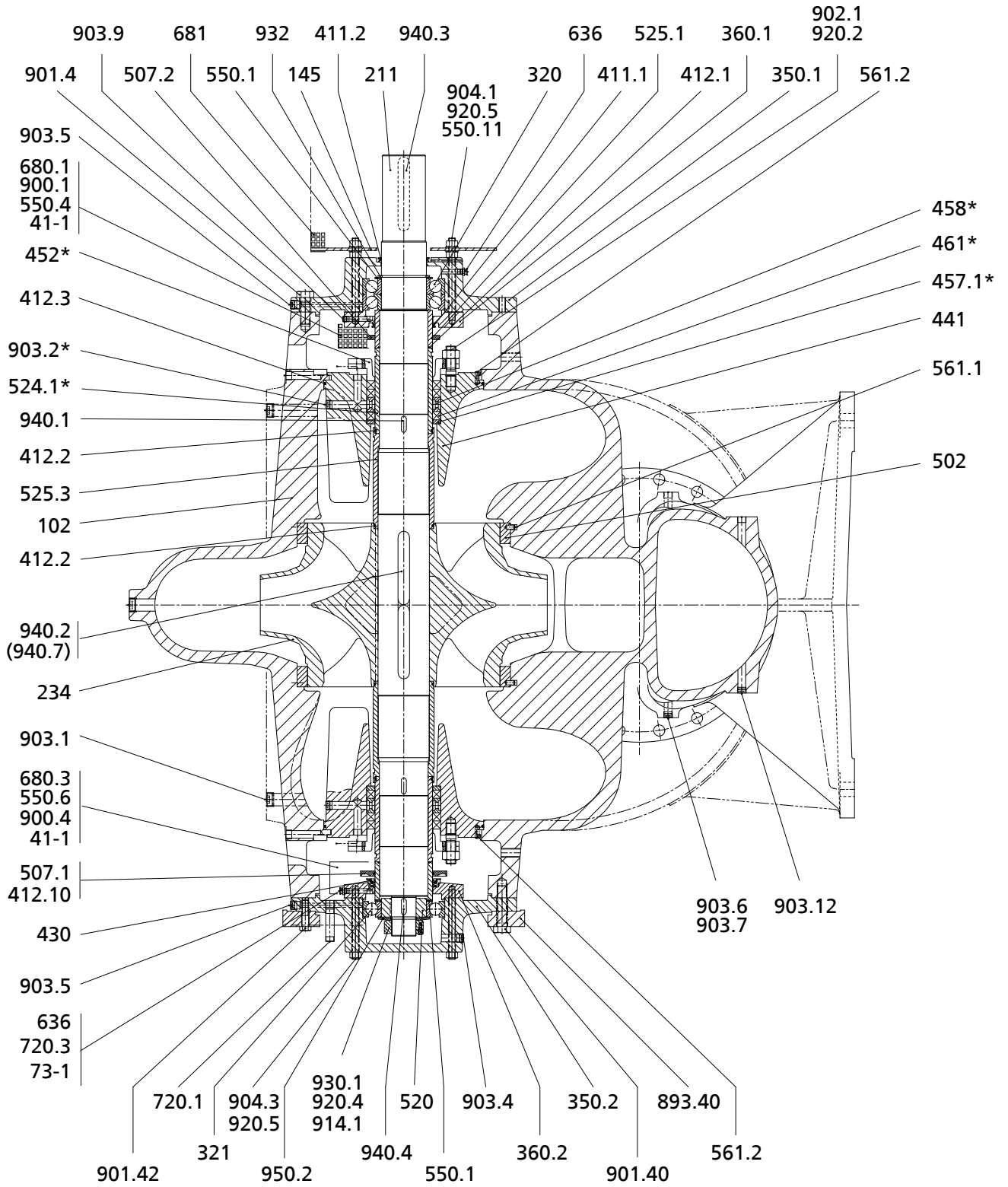

Vertical installation: * = only for pump sets with gland packing for pump discharge pressure < 7 bar

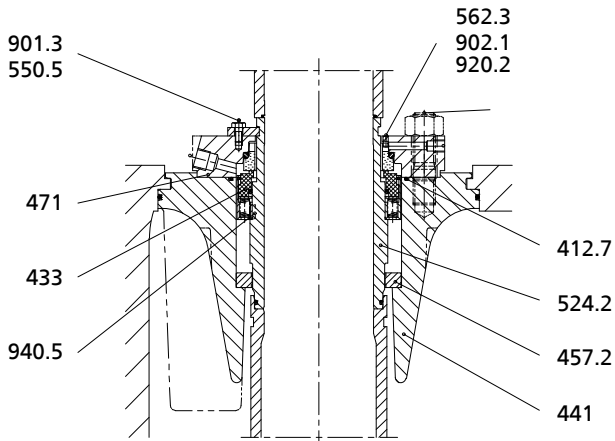

Detailed view: mechanical seal

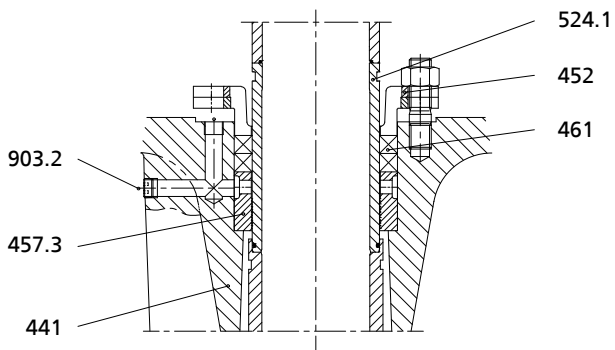

Detailed view: gland packing, pump discharge pressure ≥ 7 bar

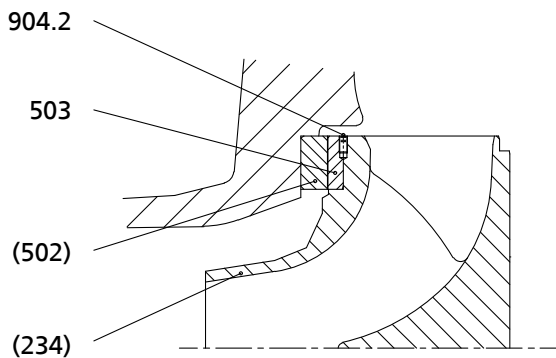

Detailed view: impeller with impeller wear ring

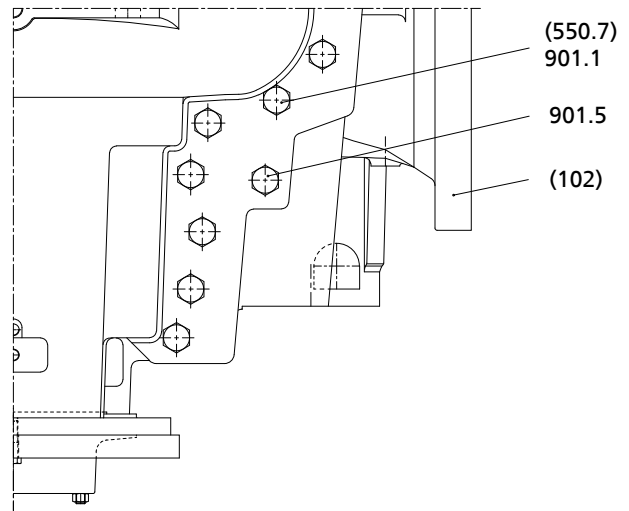

Detailed view: connecting elements of the volute casing

List of components

Part No.	Description	Part No.	Description
102	Volute casing	524.1/2	Shaft protecting sleeve
145	Adapter	525.1/3	Spacer sleeve
211	Pump shaft	550.1/4/5/6/7/11	Disc
234	Impeller	561.1/2	Grooved pin
320	Rolling element bearing	562.3	Parallel pin
321	Radial ball bearing	636	Lubricating nipple
350.1/2	Bearing housing	680.1/3	Guard
360.1/2	Bearing cover	681	Coupling guard
41-1	Sealing washer	73-1	Socket
411.1/2	Joint ring	720.1/3	Spacer
412.1/2/3/7/10	O-ring	893.40	Soleplate
430	Shaft seal	900.1/4	Screw
433	Mechanical seal	901.1/3/4/5/40/42	Hexagon head bolt
441	Shaft seal housing	902.1	Stud
452	Gland follower	903.1/2/4/5/6/7/9/12	Screw plug

Part No.	Description	Part No.	Description
457.1/.2/.3	Neck ring	904.1/.2/.3	Grub screw
458	Lantern ring	914.1	Hexagon socket head cap screw
461	Gland packing	920.2/.4/.5	Nut
471	Seal cover	930.1	Safety device
502	Casing wear ring	932	Circlip
503	Impeller wear ring	940.1/.2/.3/.4/.5/.7	Key
507.1/.2	Thrower	950.2	Spring
520	Sleeve		



KSB Aktiengesellschaft

P.O. Box 200743 • 06008 Halle (Saale) • Turmstraße 92 • 06110 Halle (Germany)

Tel. +49 345 4826-0 • Fax +49 345 4826-4699

www.ksb.com

18.11.2013

1387.5/04-EN