



PABRM15 Pump

LOWARA PUMP WITH PERIPHERAL IMPELLER

 **LOWARA**
a xylem brand

PABRM15 Pump

New and improved PABRM15 Pump which replaces the PABM 15 and is suitable for use with clean water that does not contain abrasive particles and liquids that are not chemically aggressive towards the materials from which the pump is made. The brass pump body construction guarantees against the formation of rust and oxidation. As a result of these characteristics these pumps are suitable for use in industrial applications such as cooling, conditioning and boiler feed. The pump should be installed in an enclosed environment, sheltered from inclement weather.



Performance range:

- Flow rate up to 40 l/min (2.4 m³/h)
- Head up to 35 m
- Class F insulation
- Protection IP 44

Application limits:

- Weight 5.7 kg
- Liquid temperature between 0°C to +90°C
- Ambient temperature between -10°C to +40°C
- Max. working pressure 6 bar

Specifications:

Pump Body	Brass
Body Plate	Brass
Motor Bracket	Brass
Impeller	Brass
Motor Shaft	Stainless steel AISI 416
Mechanical Seal	Ceramic-graphite

Characteristic curve and performance data
50 Hz n = 2900 1/min HS = 0m:

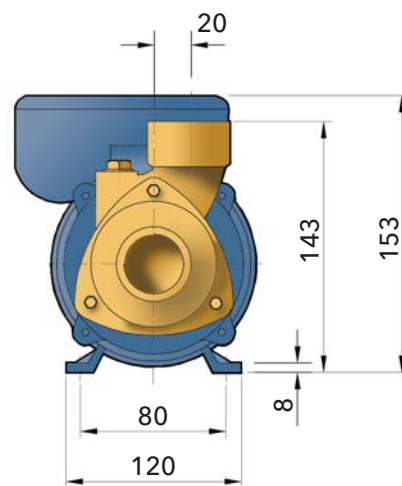
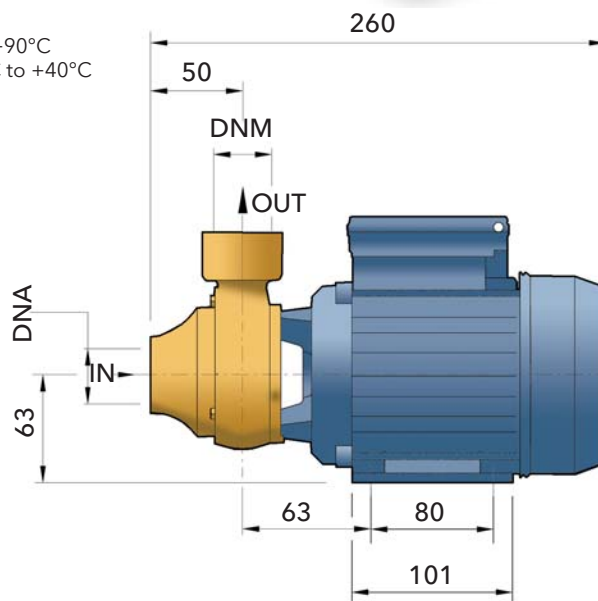
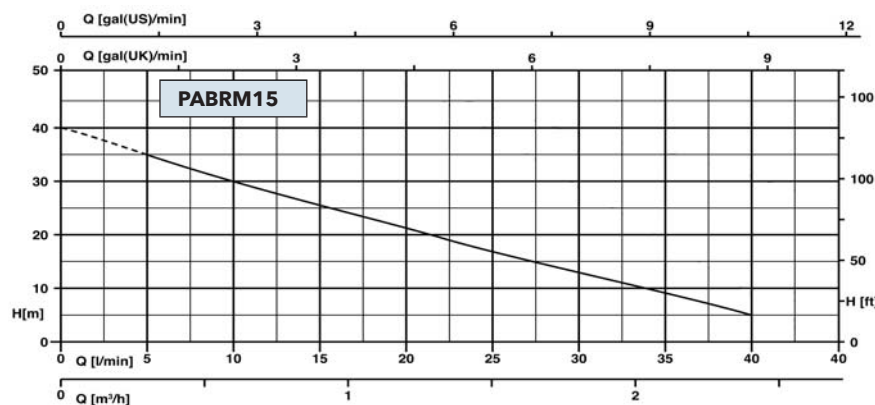

Model	Power		P1 (kW)	Input current	Q	m ³ /h	0.3	0.6	1.2	1.8	2.4	3
	kW	HP				1 ~	5	10	20	30	40	50
PABRM15	0.37	0.37	0.5	2.3A	H (m)	35	30	21	13	5	-	-

Q = Flow rate H = Total manometric head HS = Suction height Tolerance of characteristic curves in compliance with EN ISO 9906 App. A.



Xylem Water Solutions UK Limited
 Millwey Rise Industrial Estate
 Axminster, Devon EX13 5HU - UK
 Tel: (+44) 01297 630230
 Fax: (+44) 01297 630270
 e-mail: lowaraukenquiries@xyleminc.com
<http://www.lowara.co.uk>
<http://www.xyleminc.com>

Xylem Water Solutions Ireland Limited
 50 Broomhill Close
 Airtown Road
 Tallaght - Dublin 24
 Tel: (+353) 01 4524444
 Fax: (+353) 01 4524795
 e-mail: lowara.ireland@xyleminc.com
<http://www.lowara.ie>

Lowara is a trademark of Xylem Inc. or one of its subsidiaries. © 2014 Xylem, Inc.
 Lowara reserve the right to make modifications without prior notice.